



TYPICAL

GC6180 SERIES

HIGH SPEED SINGLE NEEDLE LOCKSTITCH MACHINE
WITH AN AUTOMATIC THREAD TRIMMER
INSTRUCTION BOOK/PARTS CATALOGUE

XI'AN TYPICAL INDUSTRIES CO., LTD.

※NOTE (Fig. 1)

Before putting a new machine into operation, remove the plugs(A) on the top of the arm and replenish sufficient amount of oil, then lift the presser foot and run the machine at a low speed of 2000 spm to check oil distributing condition through oil check window. When lubricating is normal, keep the machine run in at this speed for 30 minutes, then increase the running speed gradually. After one month run –in operation, the machine can be run at the Max speed under normal working condition.

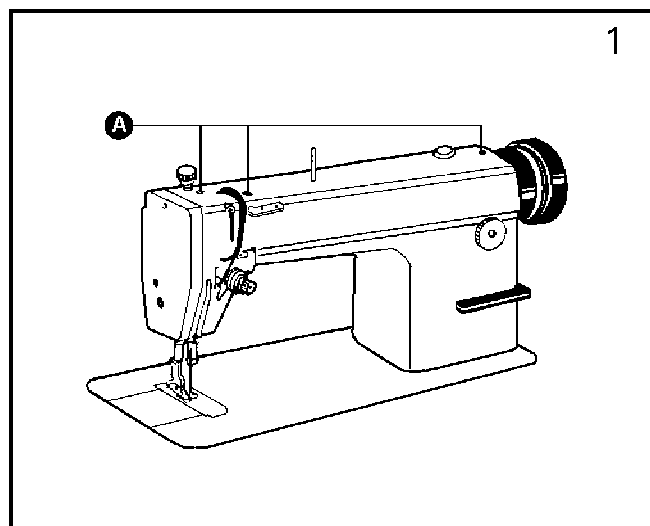

1. OIL FILLING (Fig. 2)

(1) The oil amount in the oil reservoir is controlled through the reference marks A and B shown in Fig2. The mark A indicates the max oil amount level, the mark B for the min .oil amount level .If the oil amount level is under the mark B replenish the oil reservoir with oil in time .

(2) When filling oil, loosen the oil draining screw (c), drain off the remaining oil in the oil reservoir completely, clean the oil reservoir and tighten the oil draining screw(c), then fill the oil reservoir with fresh oil.

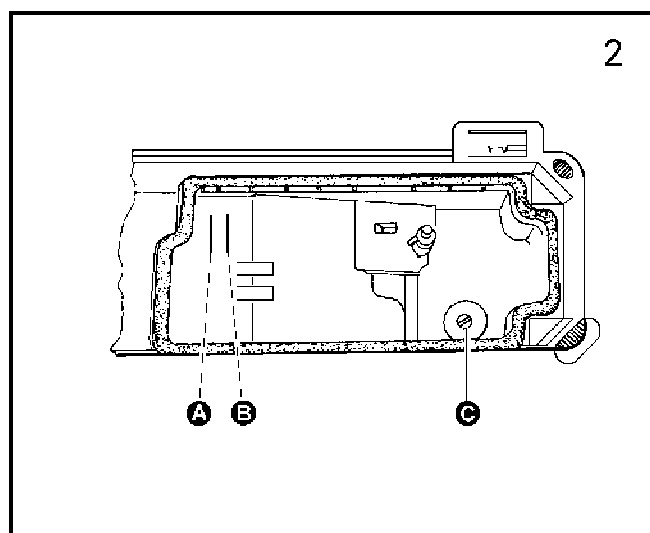

2. ROTATING HOOK OIL AMOUNT ADJUSTMENT (Fig. 3)

Adjust the oil amount of the rotating hook by turning the oil amount adjusting screw (A). Turn the screw(A) clockwise (in the “+” direction) to increase the oil amount ; turn it counter-clockwise (in the “-” direction) to decrease the oil amount.

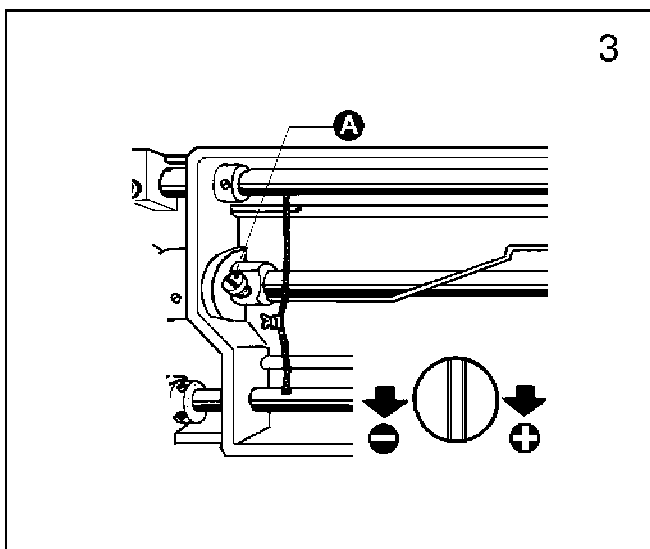

3. OIL PUMP ADJUSTMENT (Fig. 4)

In ordinary operation, adjustment is not required for the oil pump. If oil splashing does not occur in the oil check window when the machine runs at a low speed, close the clearance of the bypass oil hole.

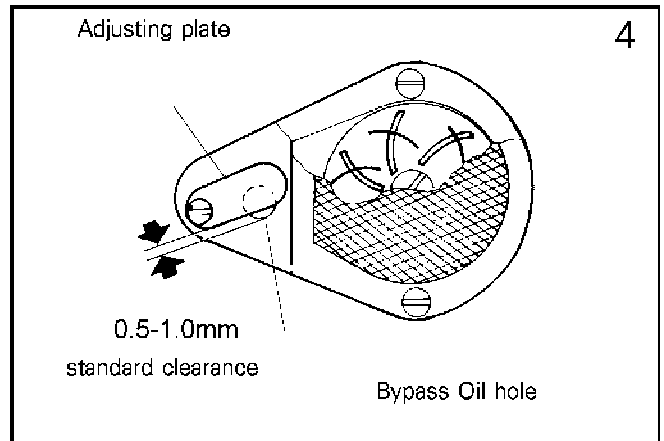

4. NEEDLE INSTALLATION (Fig. 5)

Turning the balance wheel to lift the needle bar to the upper end of its stroke. Loosen the needle clamp screw while keeping the long groove of the needle leftward, fully insert the needle shank up to the bottom of the needle socket, then tighten the needle clamp screw.

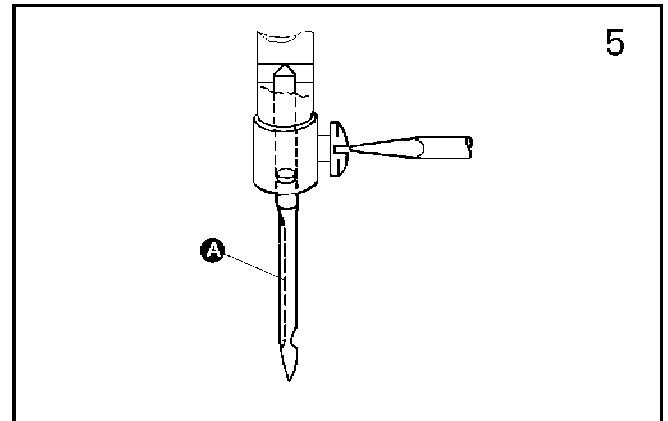

5. CONNECTION OF THE CLUTCH LEVER WITH THE PEDAL (Fig. 6)

(1) The optimum tilt angle of pedal is approximately 15 deg.

(2) Adjust the clutch so that the clutch lever (c) align with the draw bar (B) as shown in Fig. 6

(3) The machine pulley should rotate counter clockwise when viewed from the outside of it. The rotating direction of motor pulley can be reversed by turning the plug of the motor at 180 deg.

(4) Adjust the tension of O-Belt (F) by moving the motor up and down, the proper tension of the O-belt is a slack of 10-20 mm when the belt is depressed at the center of the belt by finger.

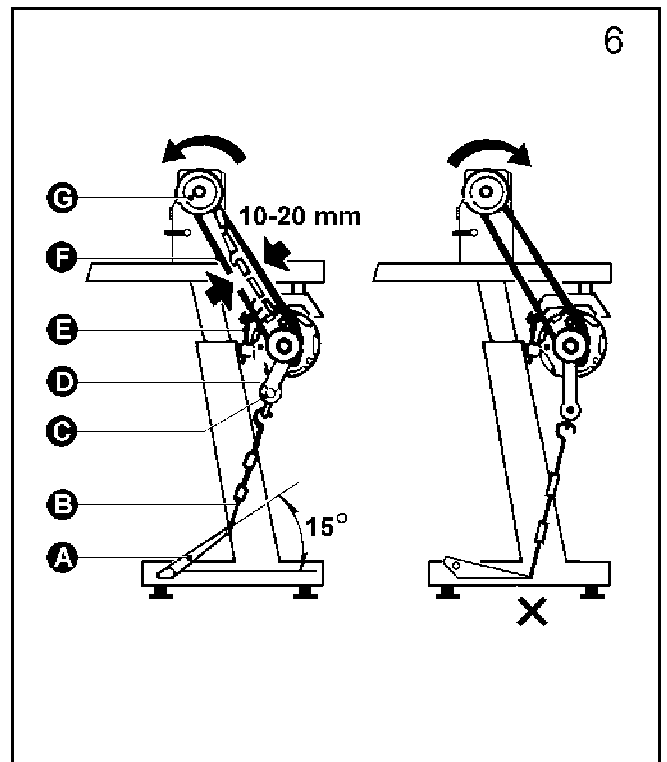

6. BELT COVER INSTALLATION (Fig. 7)

Install the belt cover for the sake of safety.

Install belt cover (C) to arm with screw (A) and screw (B), and install belt cover (E) on board with screw (D).

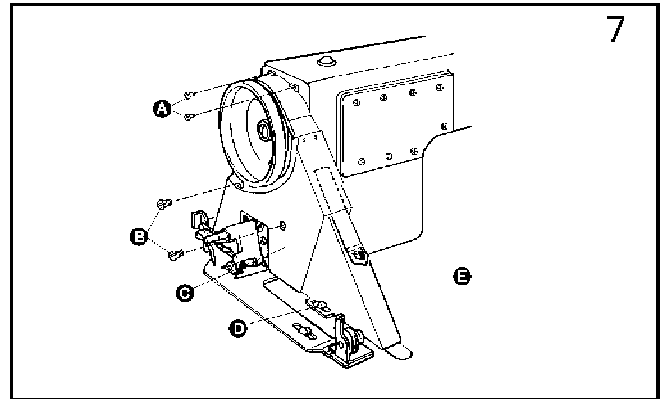

7. ADJUST THE OPENING TIME OF THE TENSION DISCS (Fig. 8)

Within the presser foot lift range, the opening time of the tension discs can be adjusted as follows:

(1) Remove the rubber plug from the back of the arm and Loosen the screw (A) of the knee lift level (left)

(2) Move the tension releasing cam (D) leftward for earlier opening or rightward for Later opening.

It will facilitate the adjustment if putting a block under the presser foot lift.

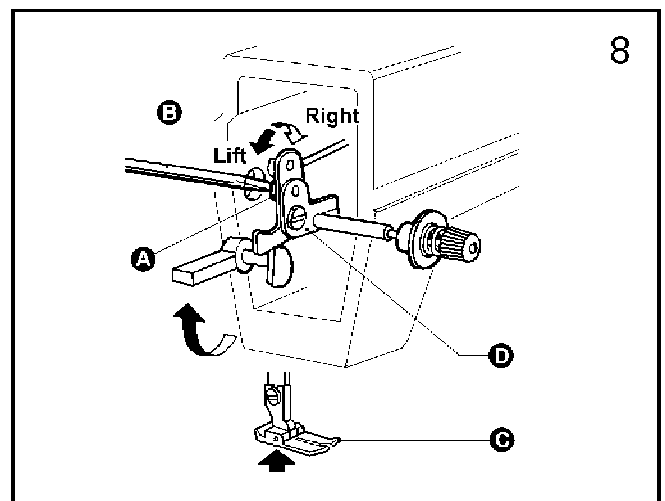

8. THREADING (Fig. 9)

To thread the needle thread, raise the needle bar to the upper end of its stroke, lead the thread from the spool and perform threading as shown in Fig 9. To draw the bobbin thread, hold the end of the needle thread and turn the balance wheel to lower the needle bar and then lift it to its highest position. Pull the ends of needle thread and bobbin thread frontward under presser foot.

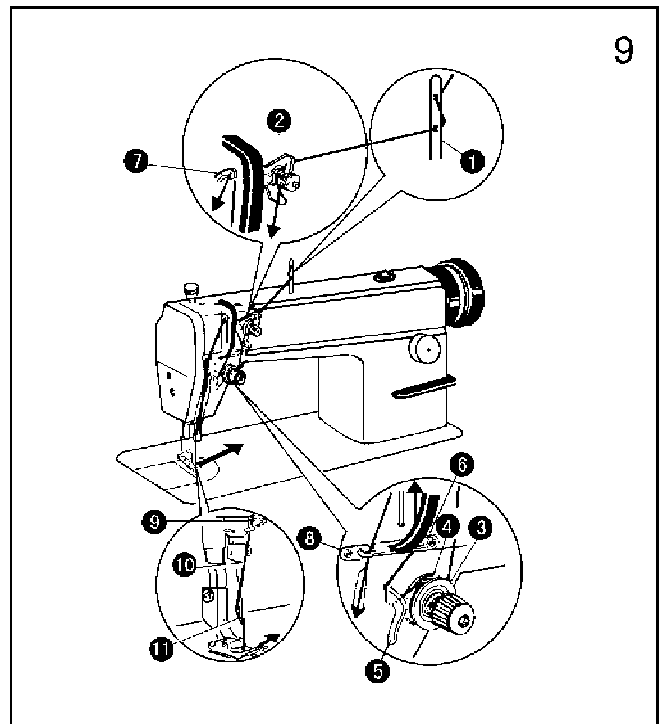

9. WINDING INSTALLATION AND ADJUSTMENT (Fig. 10)

The bobbin winder pulley should align with the V-belt and there should be some clearance between them. When the bobbin winder stop latch lever is depressed, the V-belt should be in touch with the bobbin winder pulley in order that the bobbin winder pulley can be driven by the V-belt.

The thread wound on the bobbin should be neat and tight if not tight, adjust the winding tension by turning the tension stud nut (A) of the bobbin winder tension bracket, when the thread wound on the bobbin does not present a cylindrical shape as shown in Fig. 10 (a), Loosen the set screw (B) of the bobbin winder tension bracket and move the bracket (C) leftward or rightward, if the thread is wound as shown in the figure (b), move the bracket leftward or rightward of wound as shown in the figure (c), move it leftward. After positioning the bracket adequately, tighten the set screw (B)

Do not overfill the bobbin, The optimum wound length of the thread will fill about 80% of the bobbin capacity. This can be adjusted by the screw (E) of the bobbin winder stop latch.

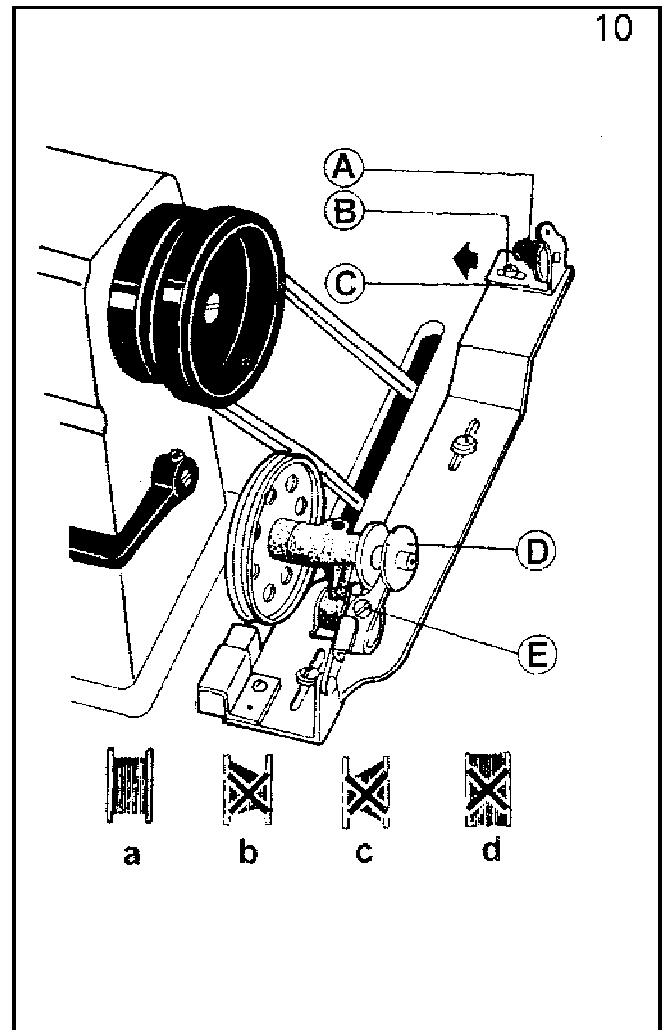

10

10. ADJUST THE PRESSURE OF PRESSER FOOT (Fig. 11)

Pressure of the presser foot is adjusted in accordance with thickness of materials to be sewn.

First loosen the lock nut (A), for heavy materials, turn the pressure regulating thumb screw as shown in Fig. 11 (a) to increase the pressure, while for light materials, turn the pressure regulating thumb screw as shown in Fig. 11 (b) to decrease the pressure, then tighten the lock nut (A).

The pressure of the presser foot is recommended to be less as long as normal feeding is ensured.

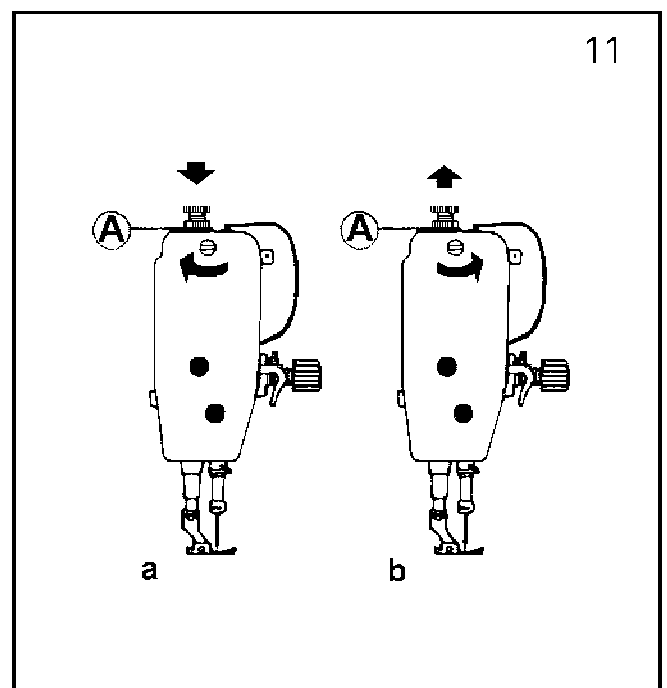

11

11. THREAD TENSION ADJUSTMENT (Fig. 12, 13, 14)

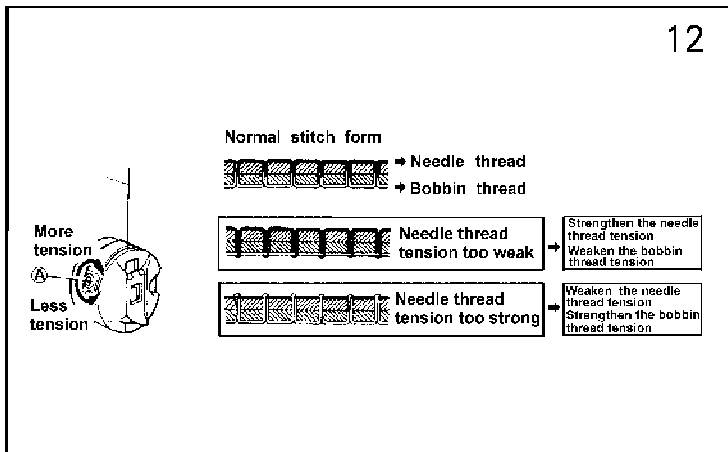

Thread tension should be determined in accordance with the stitch obtained by adjusting the tension of the bobbin thread and needle tension (Fig.12)..

The tension of the bobbin thread: to be adjusted by turning the tension spring regulating screw of the bobbin case, After adjusting, insert the bobbin into the bobbin case and hold the end of the thread from the bobbin case to hang the bobbin case, if the bobbin case falls slowly and evenly, the proper tension of the bobbin thread is obtained.

The tension of needle thread: to be adjusted by turning the thumb nut.

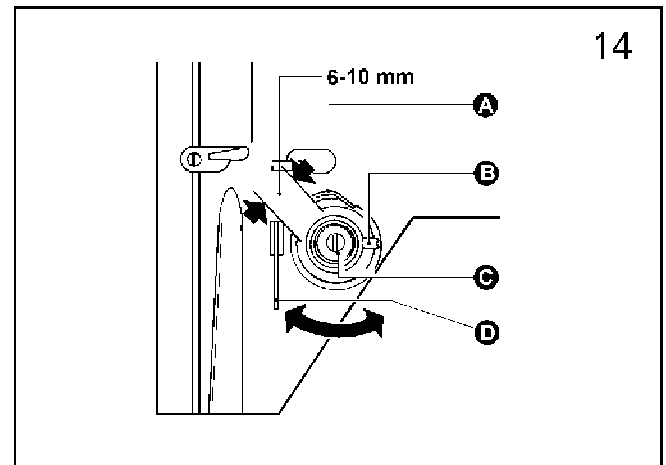
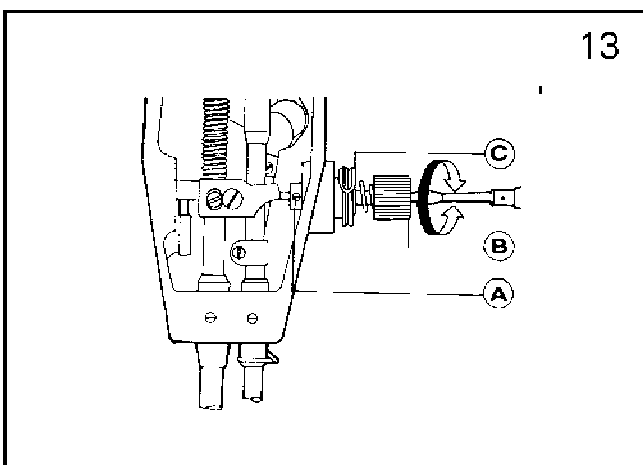

The stroke of the thread take-up spring runs from 8mm to 10mm, when sewing very thin fabrics, reduce the thread take-up spring tension and increase the thread take-up spring stroke, where as increase the thread take-up spring tension and reduce the thread take-up stroke when sewing very thick fabrics.

Adjusting the thread take-up spring tension: (Fig.13) First loosen the set screw (A), Turn the tension stud (B) counter-clockwise to decrease the tension of the thread take-up spring (C) to zero, then turn the tension stud (B) clockwise till the spring (C) comes to the notch of the tension regulating bushing, and again turn the tension stud (B) halfway back (counter clockwise), After the adjustment, tighten the set screw (A).

Adjusting the thread take-up spring stroke: (Fig.14) loosen the set screw (B) turn the stud (C) clockwise to increase the stroke or turn stud (C) counter-clockwise to decrease the stroke After the adjustment, tighten the set screw (B).

12. ADJUST THE SYNCHRONILATION OF THE NEEDLE WITH ROTATING HOOK (Fig. 15, 16)

When lifting the needle bar from its lowest position of the stroke to the distance A, the hook point D of the bobbin should align with the center line of the needle and be 1.0-1.5 mm above upper end of the needle eye (Fig. 15)

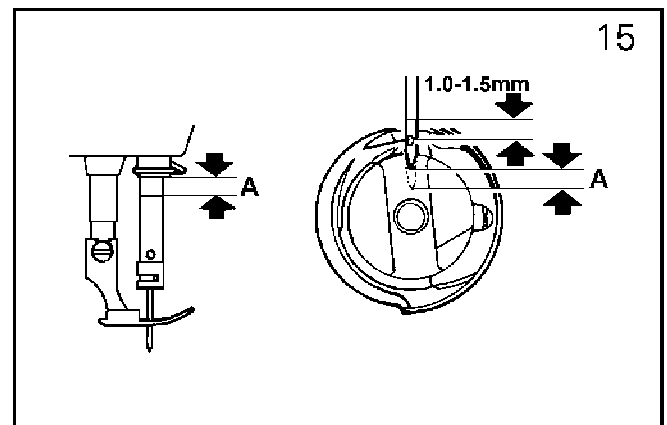

The clearance between the bottom of the needle notch and the hook point should be approx 0.05 mm (Fig. 16).

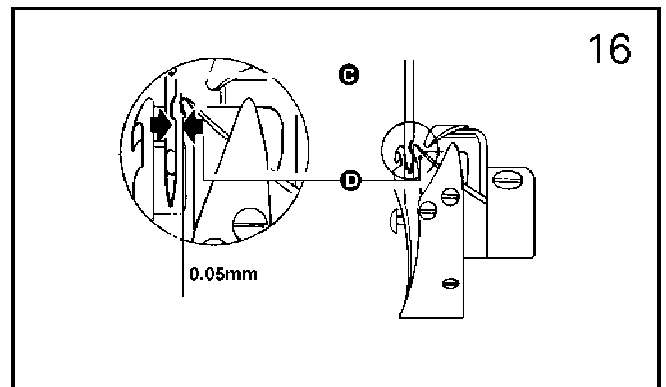

Model	M	H	B
A	2	1.8	1.8

13. ADJUSTMENT OF STITCH LENGTH AND REVERSE FEEDING (Fig. 17)

The stitch length can be adjusted by turning the dial (A). The figures on the face (B) of the dial show the stitch length in mm. the reverser feed lever must be depressed by another while adjusting the stitch length. The reverse feeding starts when the reverse feed lever (c) is depressed, the machine will feed forward again if the reverse feed lever is released.

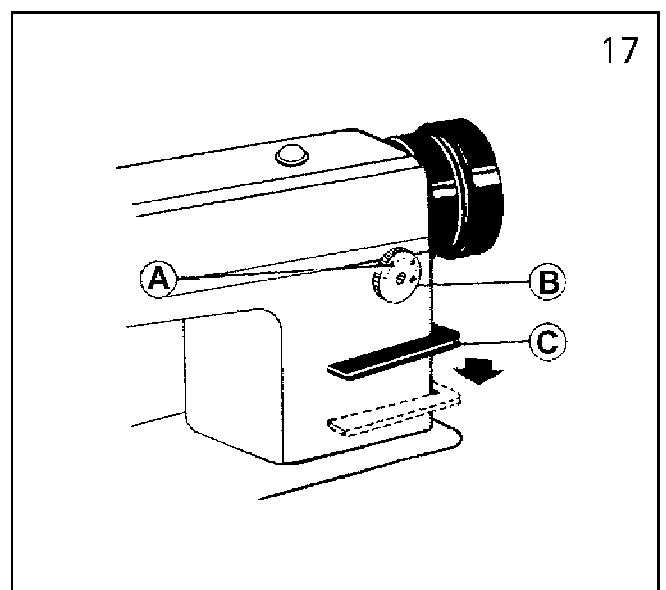

14. ADJUSTING THE POSITION OF FEED DOG AND NEEDLE (Fig. 18. 19)

Turn the balance wheel, and lower Feed Dog (A). When the top of the feed dog is flush with Throat Plate Surface (B), Needle Point (C) should be 3mm below the throat plate surface.

The adjustment should be made by adjusting the position of the feed cam and feed lift cam.

The standard position is shown in Fig. 19. for the third screw (A) of feed cam and the second screw (B) of feed lift cam to Arm Shaft Oil Hole (C) according to the direction of the balance wheel turning.

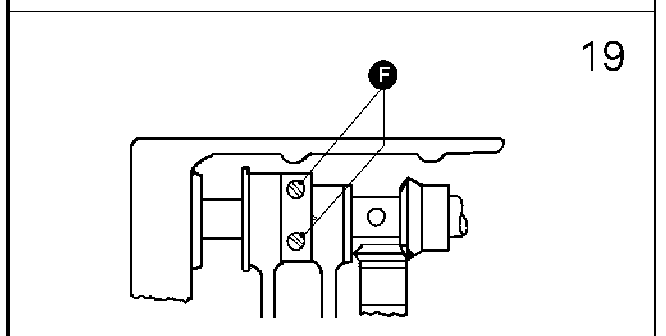
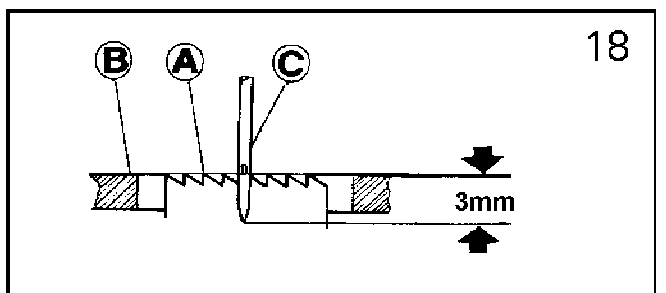

15. STITCH LENGTH ERROR ADJUSTMENT (Fig. 20)

Loosen Screw (A) to adjust Stitch Length Adjusting Cam (B). Turn it rightward to narrow the stitch length as forward sewing, and widen it as reverse sewing; turn it leftward to widen the stitch length as forward sewing, and narrow it as reverse sewing.

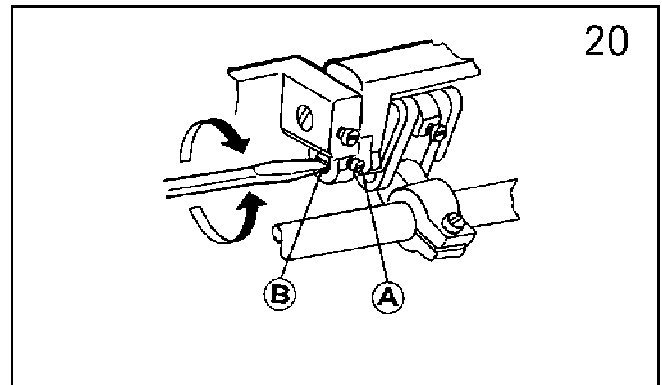

16. FEED DOG HORIZONTALITY ADJUSTMENT (Fig. 21)

To lift the front of feed dog to prevent fabric from wrinkling. To lower the front of feed dog to prevent fabric from defection, breaking of bobbin thread.

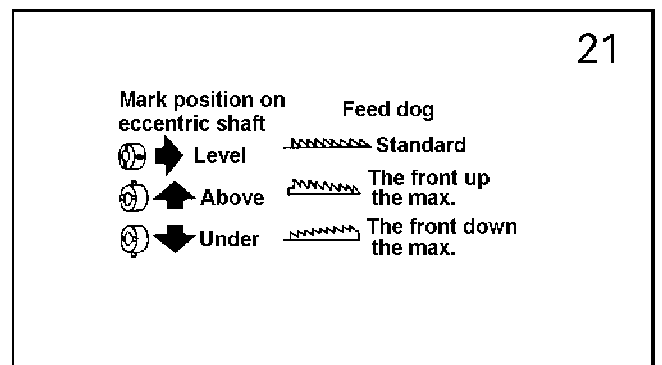

17. THREAD CUTTING MECHANISM (Fig. 22)

It adopts hook shaft cam driving for thread cutting. If thread cutting electromagnet works, and after finish thread trimming, reset thread cutting cam crank at once, otherwise may cause the movable knife and needle into collision, and damage them.

- A – fixed knife support asm.
- B – knife support asm. (left)
- C – thread cutting cam.
- D – thread cutting electromagnet.
- E – soft thread.
- F – electromagnet asm.
- G – stopper.
- H, I – thread cutting cam crank.
- J – cutter driving shaft.
- K – cutter driving crank.
- L – knife (left).
- M – fixed knife.
- N – thread retainer.

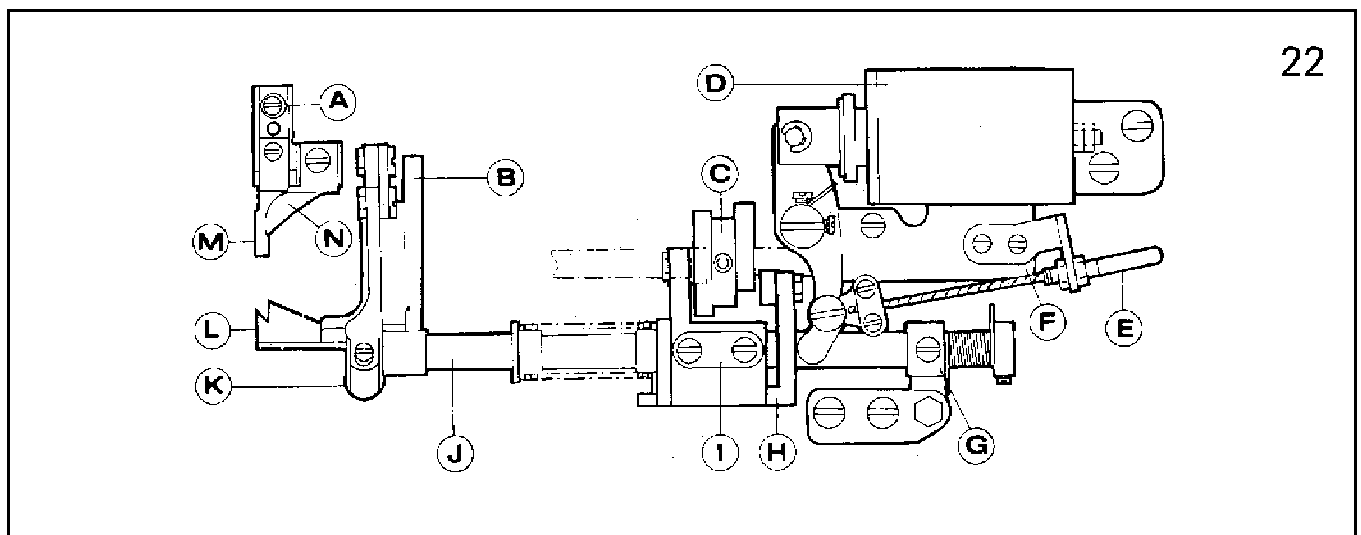

18. KNIFE SUPPORT ASM(left) (Fig. 23)

Insert the left knife support asm. (left) (B) into Hook Shaft Bushing (C) as the figure shows, then tighten screw (A).

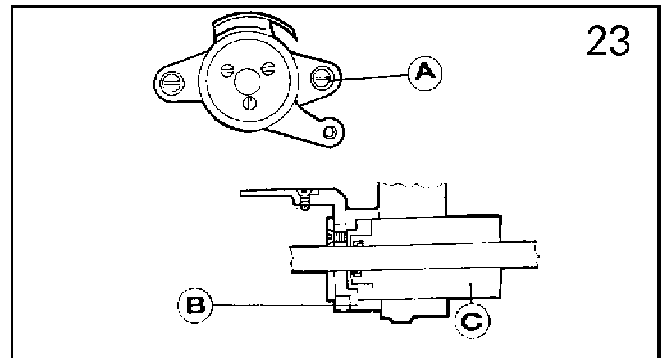

19. FIXED KNIFE SUPPORT ASM (Fig. 24)

Remove the hook positioner, then set it with screw (A) shown in Fig 24.

B – fixed knife support asm.

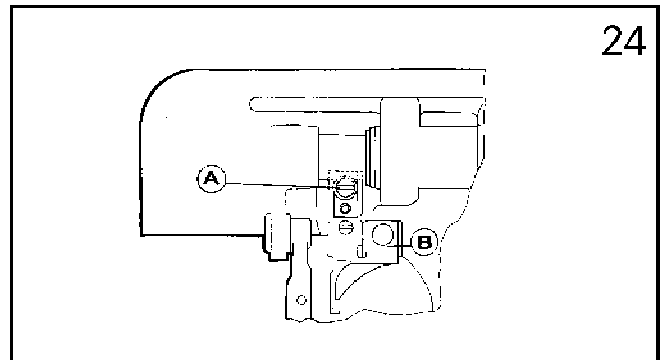

20. POSITION OF THE FIXED KNIFE AND LEFT KNIFE POINT (Fig. 25)

(1) The standard position is shown in the figure.

(2) If the size is larger than the standard, the knife will cut the 3 threads in the meantime or draw the thread out of the needle eye; if smaller, will cause cutting damage, so make sure to avoid that.

(3) As things mentioned above occur, adjustment is done by setting the fixed knife support or the fixed knife (B).

A – the blade C – the knife (left)

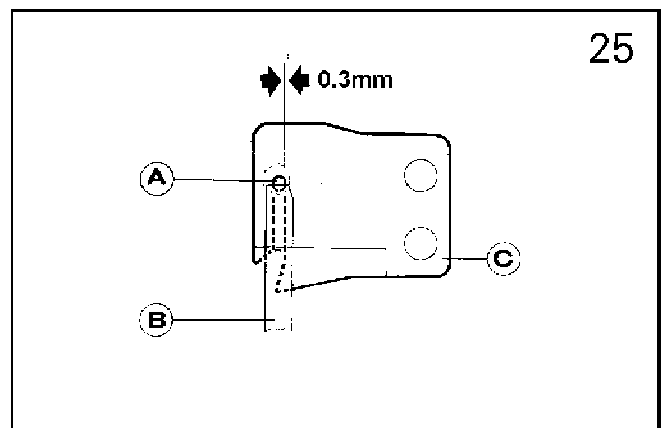

21. CONNECTION OF THE KNIFE (LEFT) SUPPORT AND CUTTER DRIVING CRANK (Fig. 26)

Connect them as the figure shows and notice the position of Cutter Link Lever (A).

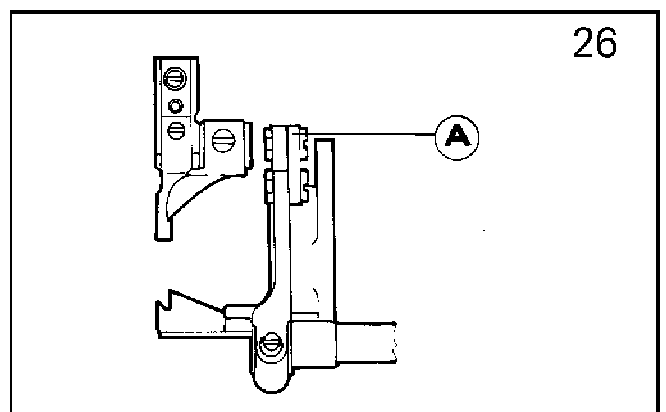

22. POSITION OF THE CUTTER DRIVING SHAFT (Fig. 27)

(1) The Standard position is shown in the figure.

(2) When assemble it, Cutter Driving Shaft (G) should be first put in Cutter Driving Crank (A).

(3) Set Thread Cutting Cam Crank 1 (D) on the cutter driving shaft with reference to the standard position.

(4) Set Stopper (F), make sure that there is no clearance between parts around the cutter driving shaft, and rotate steadily.

B – spring end cover

C – spring

E – thread cutting cam crank 2

Model	M	H	B
a	90.5mm	90.5mm	87mm

27

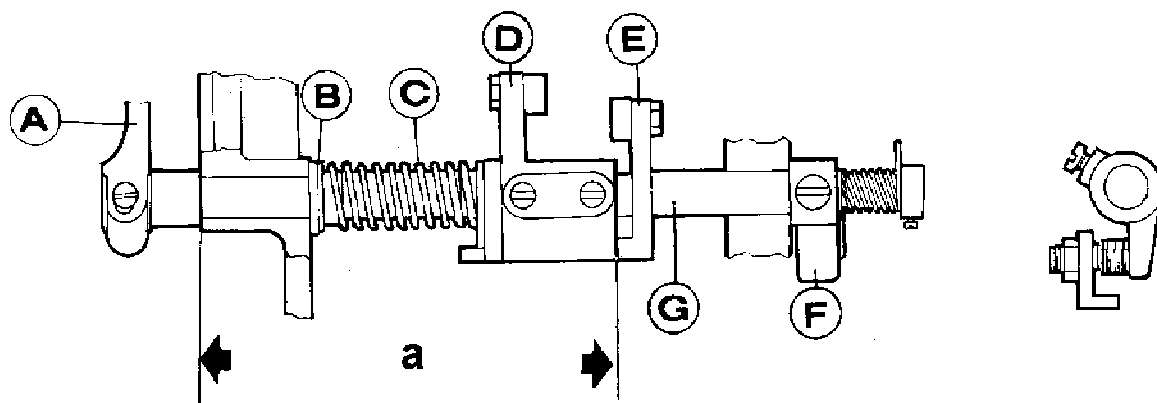

23. THE ELECTROMAGNET CORE STROKE (Fig. 28)

(1) The standard stroke of the electromagnet core is 6mm.

(2) The stroke can be adjusted with Positioning screw (A)

B – thread cutting electromagnet holder

C – thread cutting cam crank 2

D – driving bar

E – thread cutting electromagnet

28

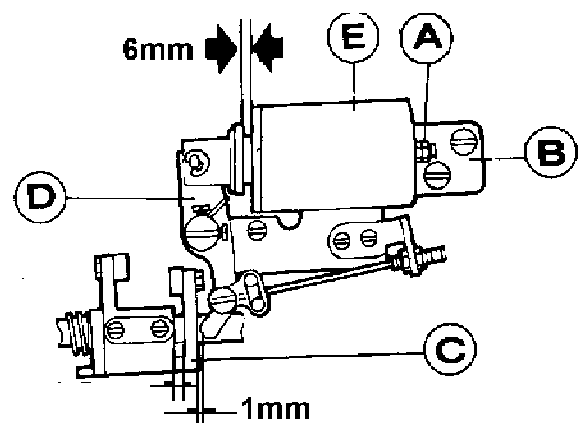

24. INSTALLING THE ELECTROMAGNET ASM (Fig. 28)

The installing parameter is shown in Fig. 28.

25. INSTALLING THREAD CUTTING CAM (Fig. 29. 30. 31. 32. 33)

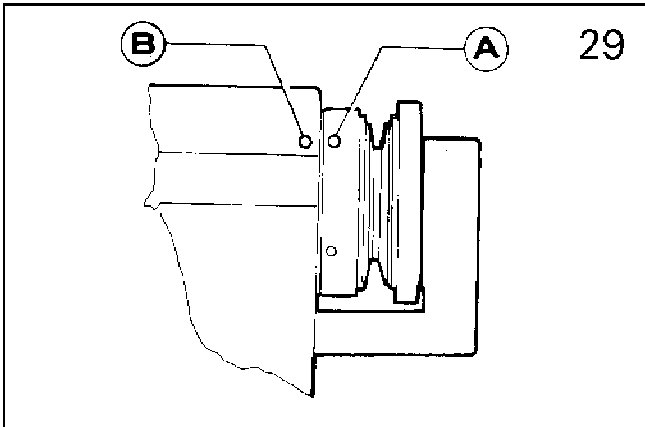

(1) Align No.2 Positioning Mark (A) on the balance wheel with Positioning Mark (B) on the machine arm.

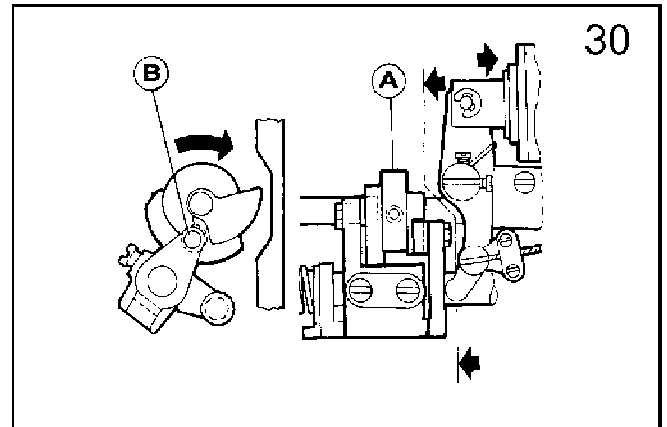

(2) As the thread cutting electromagnet works, Thread Cutting Cam (A) run in normal rotating direction. Fix the cam when Cam (A) is engaged with Roller (B).

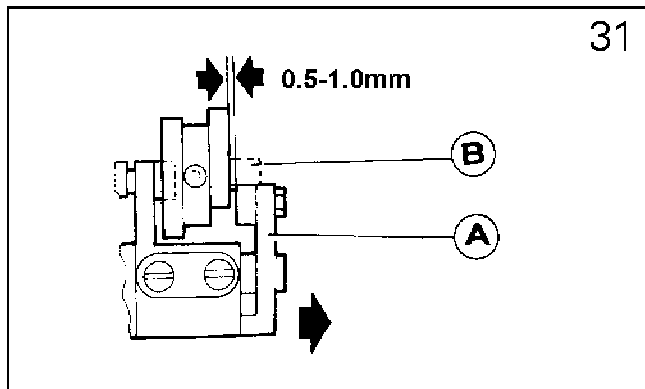

(3) Stop the operation of the electromagnet, reset Cam Driving Crank (A), Cam (B) is separated from the engagement with the roller, the standard clearance is 0.5 – 1.0mm.

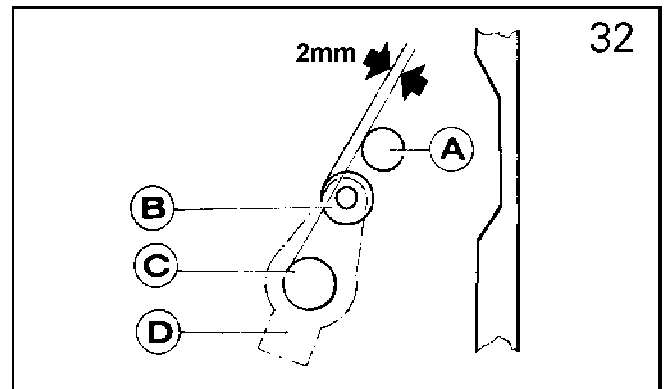

Note: the figure shows the standard position of Cam Driving Crank (D) before operation.

A – hook shaft B – roller C – cutter driving shaft

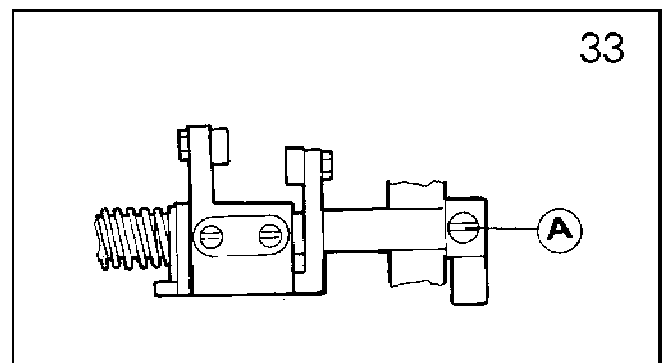
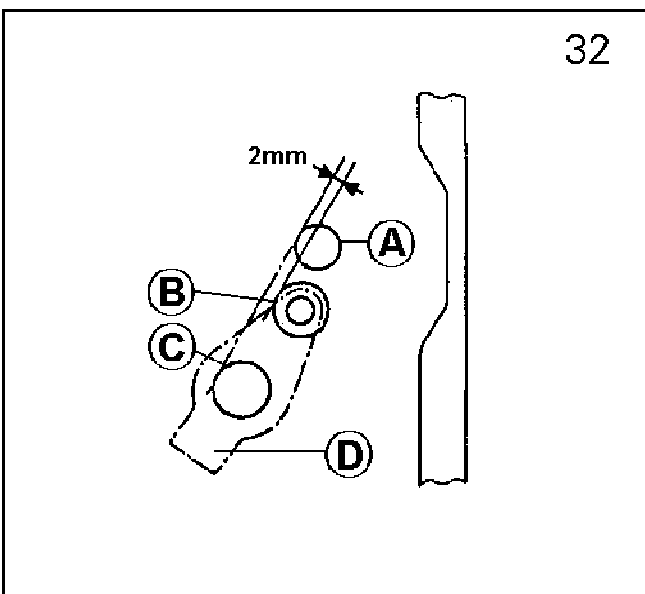

It may change the positions mentioned above to remove the stopper, then adjust with Screw (A), and readjust the above (1) – (3)

26. ADJUSTING KNIFE CUTTING ENGAGEMENT (Fig. 34. 35)

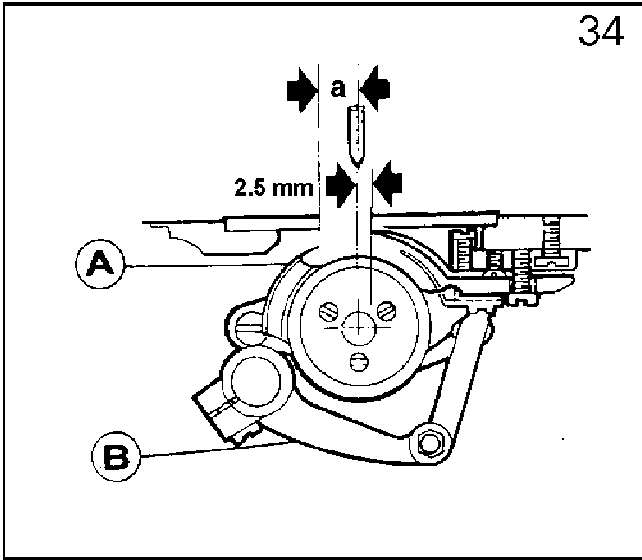

型号	M	H	B
a	7mm	7mm	7mm

(1) The figure shows the standard positions of the left knife and the fixed knife.

A – knife (right) B – cutter driving shaft

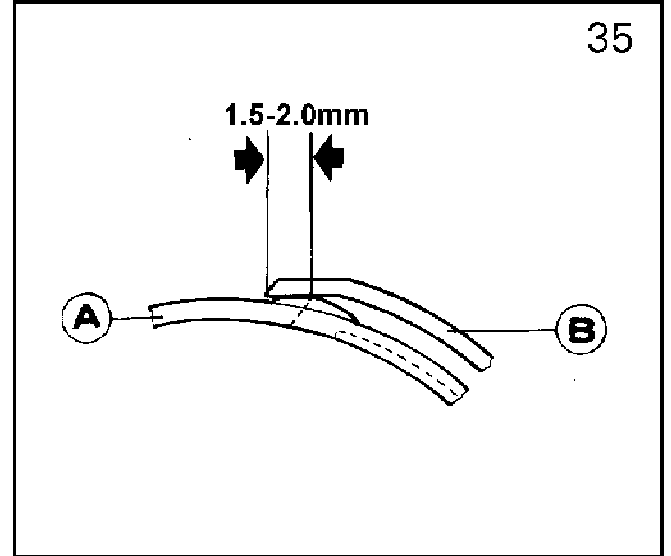

(2) Adjust the degree of knife cutting engagement: ① When the electromagnet works, turn the machine, the left knife (A) follows the motion of the thread cutting cam. The maximum degree of cutting engagement is 1.5 – 2.0mm B – the fixed knife ② Adjust the cutter driving crank if necessary.

27. ADJUSTING CUTTING PRESSURE (Fig. 36. 37)

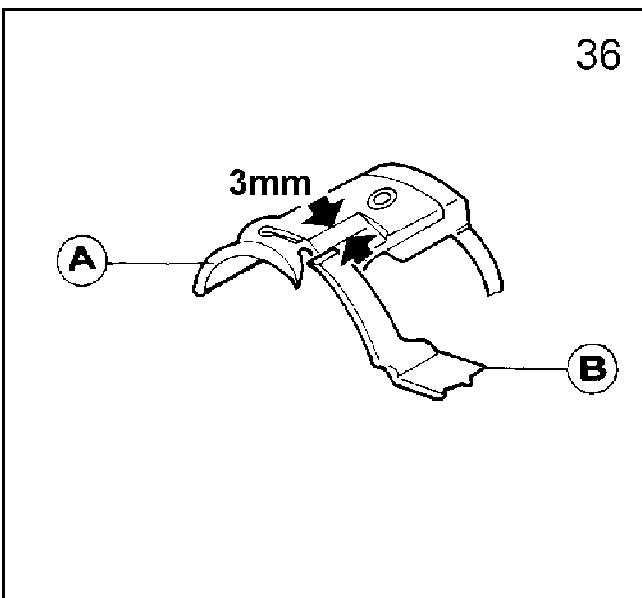

(1) The figure shows the standard position that Left Kniff (A) begins to touch Fixed Knife (B).

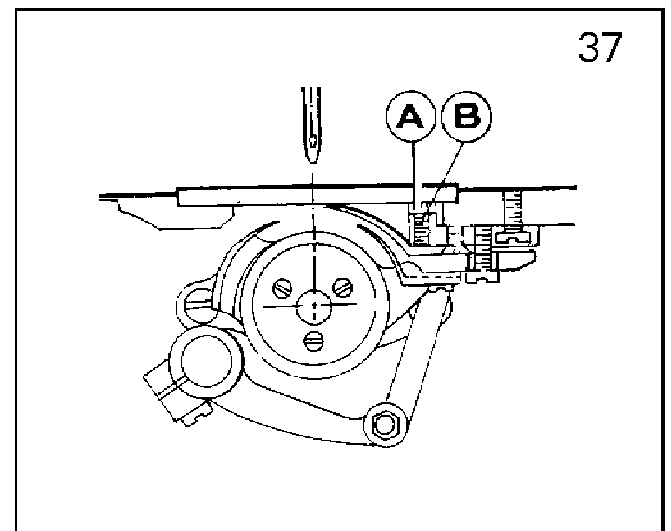

(2) When cutting thick thread, increase the cutting force.

(3) For adjusting cutting force, loosen Set Nut (A), and adjust Screw (B).

28. ADJUSTING NEEDLE THREAD TENSION (Fig. 38. 39)

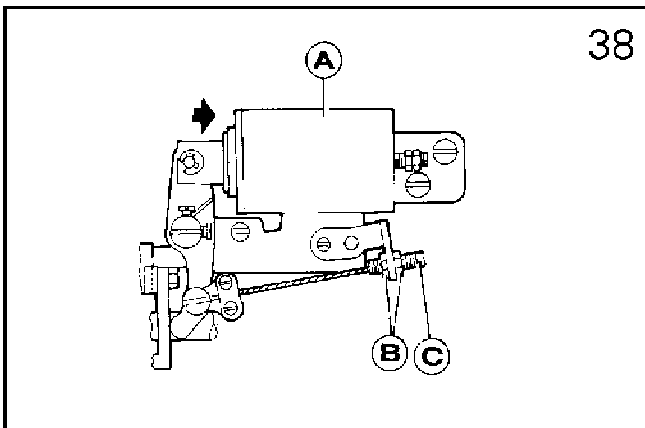

There should be a clearance of 1mm between the two discs while the thread cutting electromagnet (A) is working.

For adjustment, loosen Nut (B), and move soft thread (C).

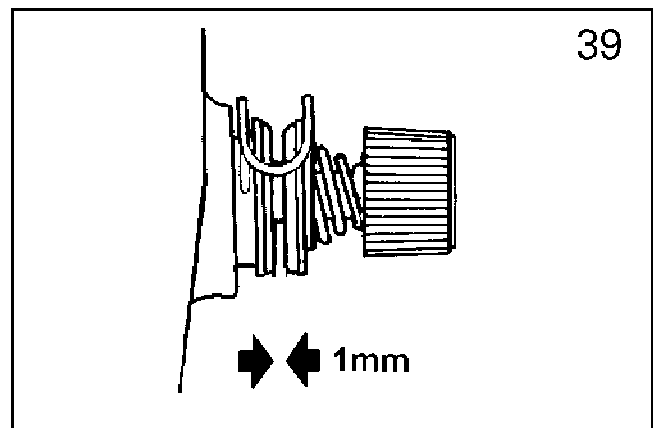

Note: If the clearance is too small, the thread end left after cutting is too short and may easily go away from the needle eye; otherwise the tension is poor and affect the needle thread tension.

29. THREAD END REMAINS ADJUSTMENT (Fig. 40)

To get the needle thread end remains properly, adjust Nut (A).

Turn rightward: get short

Turn leftward: get long

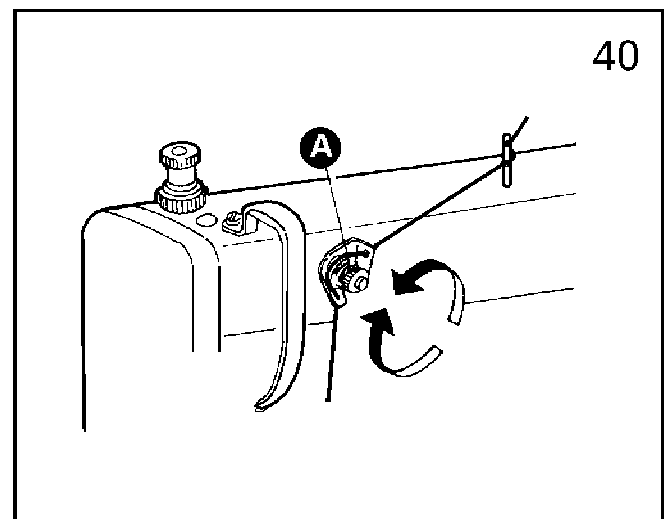

30. INSTALLING REVERSE STITCH ELECTROMAGNET (Fig. 41)

Adjust the position of Electromagnet (A) properly to guarantee the flexible connection of the magnet with the link lever and the convenient operation of Reverse Stitch Bar (B), then set with a screw.

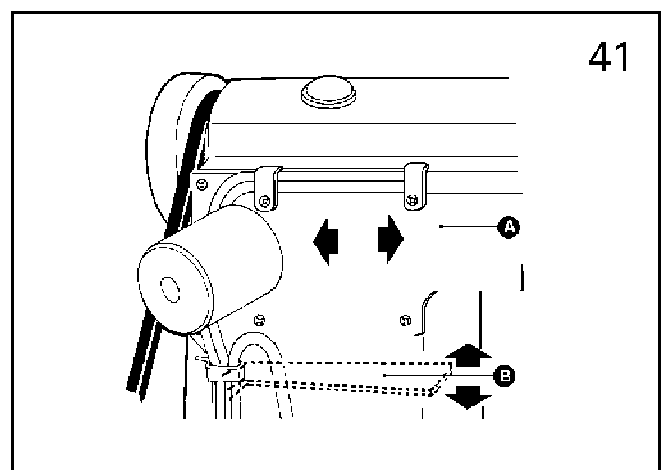

31. REVERSE STITCH SWITCH (Fig. 42)

The figure shows the normal state. It can perform reverse sewing to switch on. If move the switch to the dotted line shown in the figure, and switch on, the reverse sewing can not be performed.

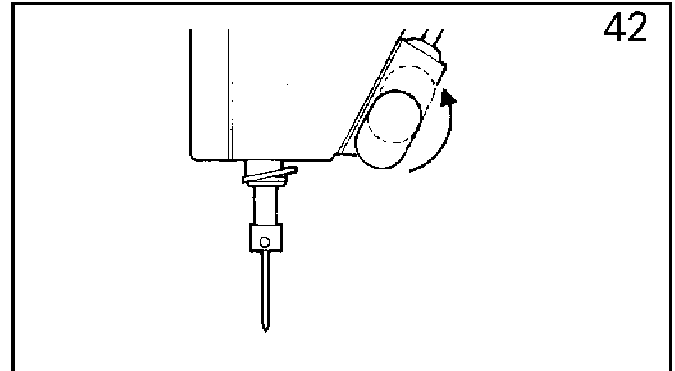

32. THREAD RETAINING DEVICE (Fig. 43, 44, 45)

1. Thread Retainer Height

(1) Standard height: 2 mm from the needle point as the needle in its highest position.

(2) To adjust Thread Retainer (B), loosen Screw (A).

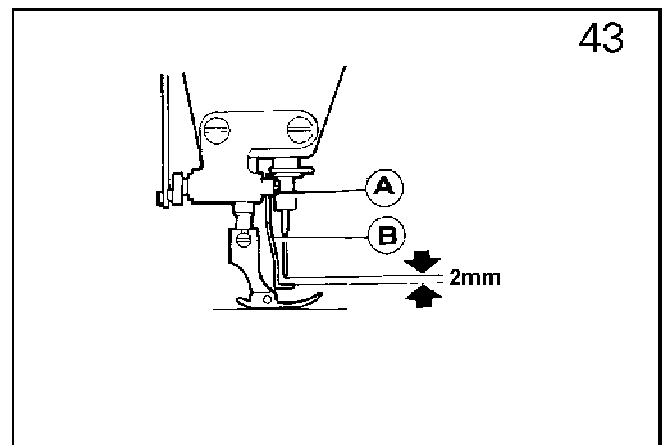

2. Thread Retainer Working position.

(1) When the magnet move into the electromagnet completely, the standard distance between the thread retainer and the center of the needle should be 0 – 2 mm.

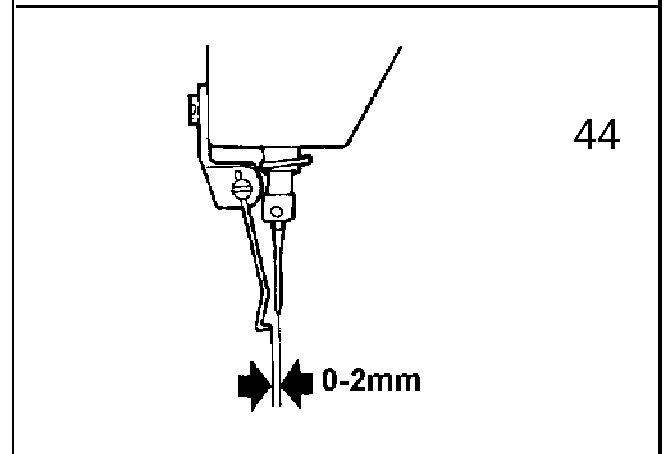

(2) To adjust its position, loosen Screw (C), Screw (B), and adjust the position of Electromagnet Asm (A).

D – magnet

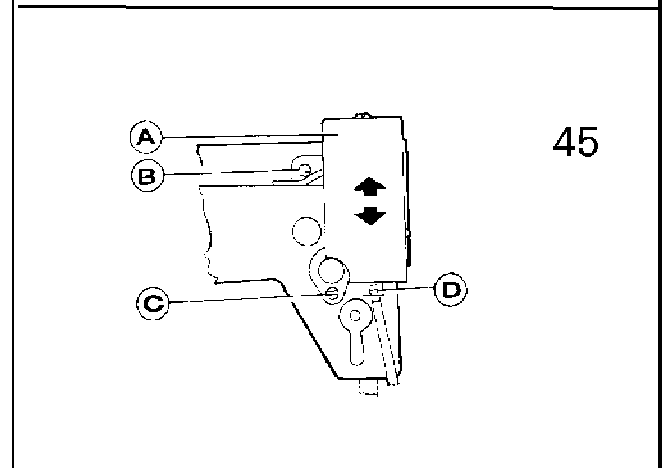

33. HOOK, BOBBIN CASE AND BOBBIN (Fig.46. 47)

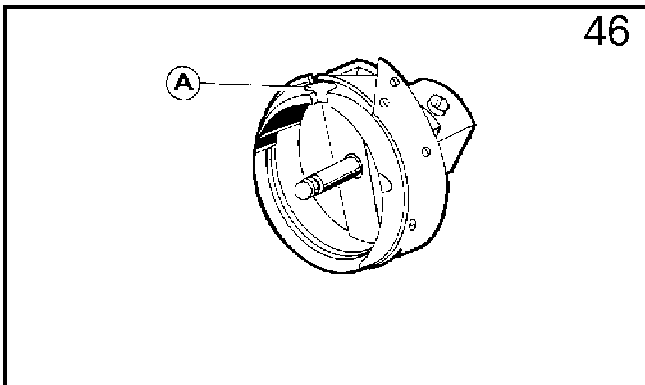

1. There is a thread groove(A) in the special hook for thread cutting sewing machine.

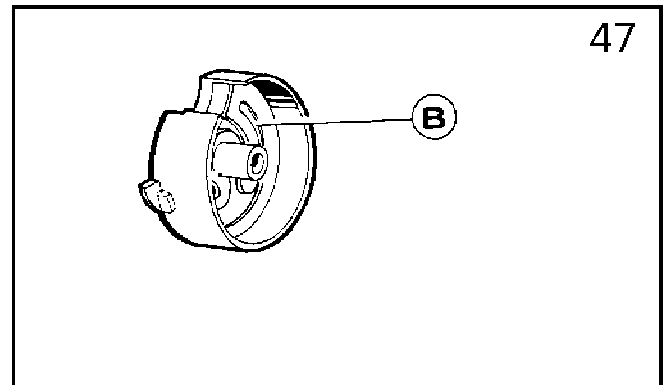

2. The bobbin case used in the machine should be with a spring(B) in its bottom, which prevents the bobbin from running without loading.

17. REGULAR CLEANING (Fig. 22. 23. 24)

1) Cleaning feed dog

Remove the throat plate and clear off the dust and lint between feed dog tooth slots.

2) Cleaning rotating hook

Swing out the machine head and clean the hook. Wipe the bobbin case with soft cloth.

3) Cleaning oil pump screen

Swing out the machine head and clear off the dust and dirt on oil pump screen.

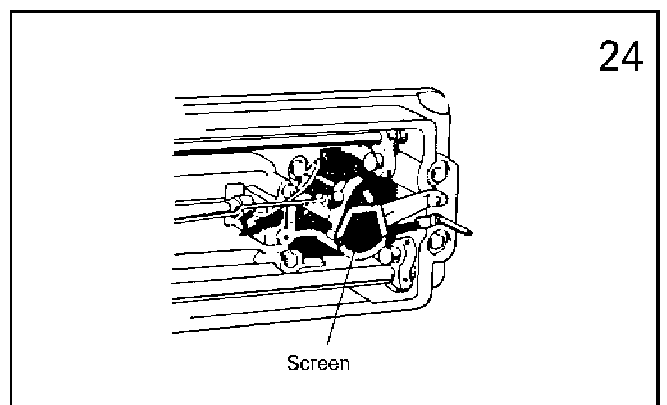
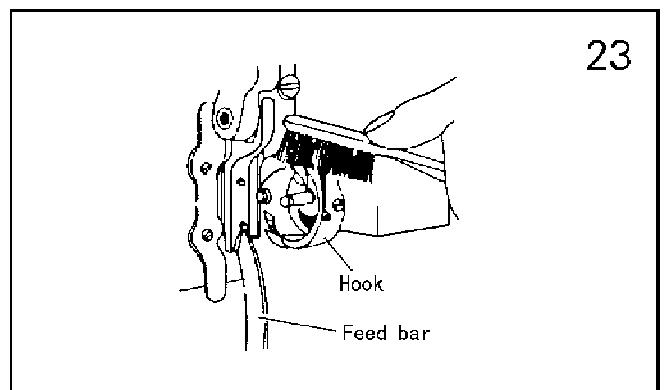
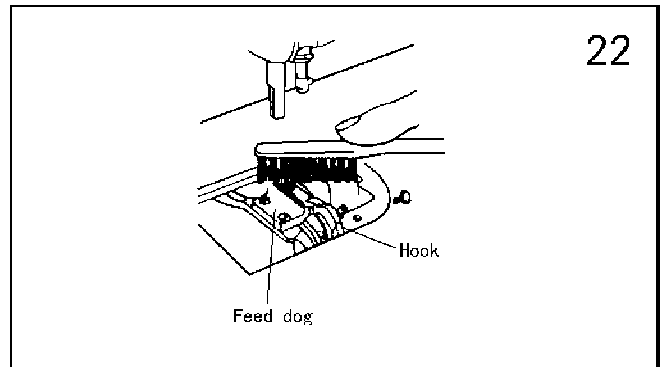

CONTENT

Instruction book	1 – 13
Parts catalogue -----	14 – 29
1. Arm and bed mechanism-----	14 – 15
2. Arm shaft and vertical shaft and thread take – up mechanism -----	16 – 17
3. Feeding and feed lifting and rotating hook mechanism -----	18 – 19
4. Stitch length regulating mechanism -----	20 – 21
5. Presser foot mechanism-----	22 – 23
6. Knife actuating mechanism	24 – 25
7. Reverse sewing and detector mechanism	26
8. Wiper mechanism -----	27
9. Oil pump mechanism	28
10. Oil reservoir and accessories -----	29

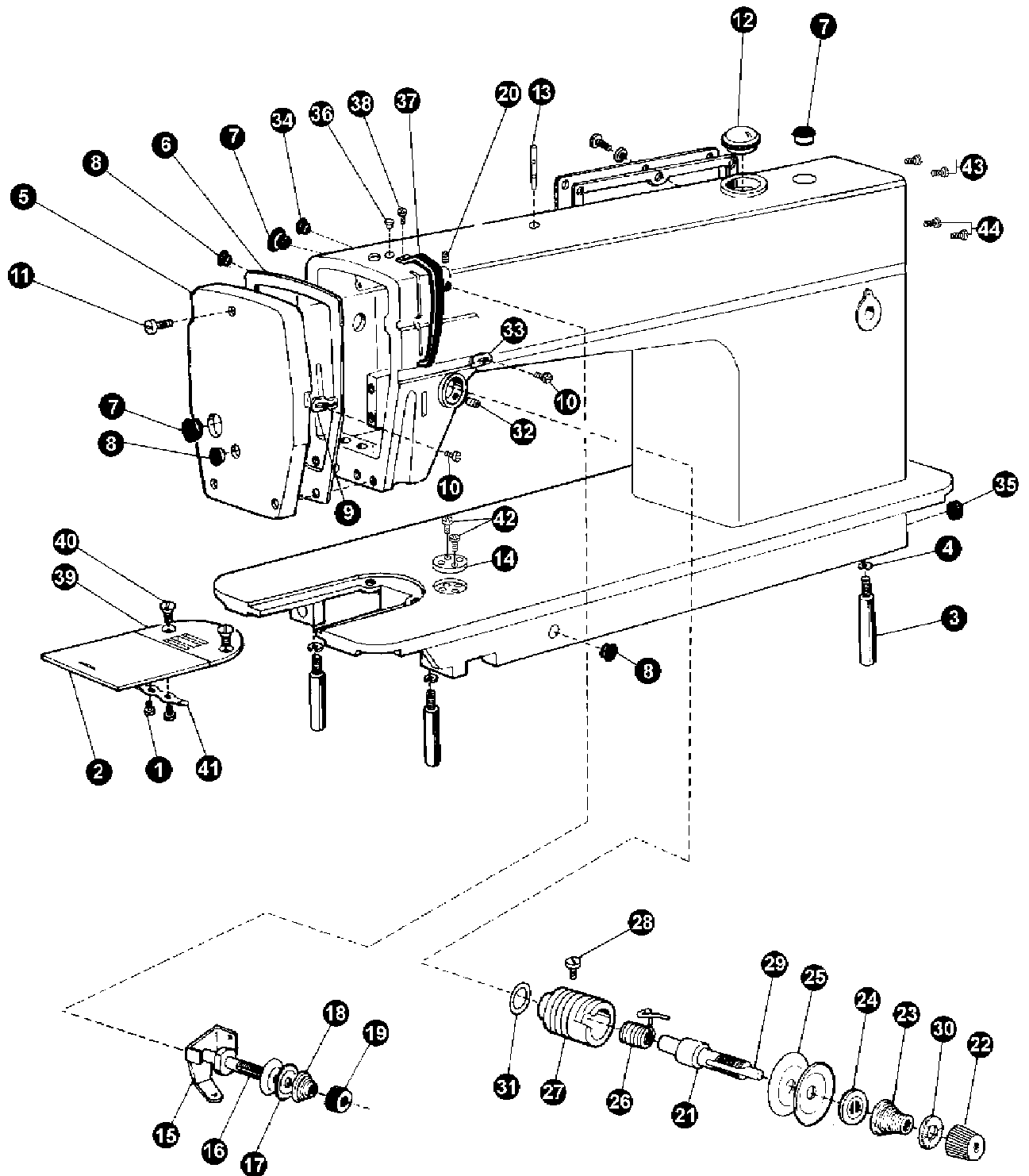

1. ARM AND BED MECHANISM

No.	Ref. No.	Description	Qt.		
			M	H	B
1	22T1 -021G3	Screw	2	2	2
2	22T1 -021G1	Slide plate	1	1	1
3	48T1 -005	Leg	3	3	3
4	GB93 -87 -6	Spring washer 6	3	3	3
5	124T1 -002B1	Face plate	1	1	1
6	124T1 -002B2	Face plate gasket	1	1	1
7	22T1 -003C3	Rubber plug	3	3	3
8	22T1 -003C4	Rubber plug	3	3	3
9	22T1 -003C5	Thread guide on face plate	1	1	
	78T1 -004C1	Thread guide on face plate			1
10	22T1 -003C6	Screw	1	1	1
11	22T1 -004	Screw	1	1	1
12	22T1 -008H	Oil check window	1	1	1
13	108200009	Three guide pole	1	1	1
14	57T1 -008	Ruler plate	1	1	1
15	36T2 -006D1	Pretension thread guide	1	1	1
16	36T2 -006D2	Thread tension stud	1	1	1
17	22T1 -009E3	Thread tension disc	2	2	2
18	36T2 -006D3	Tension spring for pretension	1	1	1
19	36T2 -006D4	Thread tension nut	1	1	1
20	124T1 -006	Set screw	1	1	1
21	22T1 -012F1	Thread tension stud	1	1	1
22	124T1 -003C1	Thread tension nut	1	1	1
23	124T1 -003C2	Thread tension spring	1		
	48T1 -003A1	Thread tension spring		1	1
24	22T1 -012F4	Thread tension releasing disc	1	1	1
25	22T1 -012F5	Thread tension disc	2	2	2
26	22T1 -012F6	Thread take -up spring	1		
	48T1 -003A2	Thread take -up spring		1	1
27	22T1 -012F7	Thread tension regulator bushing	1	1	1
28	22T1 -012F8	Screw	1	1	1
29	22T1 -012F9	Thread tension releasing pin	1	1	1
30	22T1 -012F10	Stop disc	1	1	1
31	22T1 -012F11	O - type ring	1	1	1
32	22T1 -013	Set screw	1	1	1
33	22T1 -014	Thread guide	1	1	
	78T1 -005	Thread guide			1
34	22T1 -015	Rubber plug	2	2	2
35	22T1 -016	Rubber plug	1	1	1
37	36T2 -007	Thread take -up lever guard	1	1	
	78T2 -002	Thread take -up lever guard			1
38	22T2 -004	Screw	1	1	1
39	124T1 -005	Needle plate(B1. 8)	1		
	48T1 -004	Needle plate(B2. 0)		1	
	48T1 -006	Needle plate(B2. 6)			1
	153100004	Needle plate		1	1
	153100002	Needle plate	1		
40	020100002	Screw	2	2	2
41	22T1 -012G2	Slide plate spring	1	1	1
42	1241 -004	Screw	2	2	2

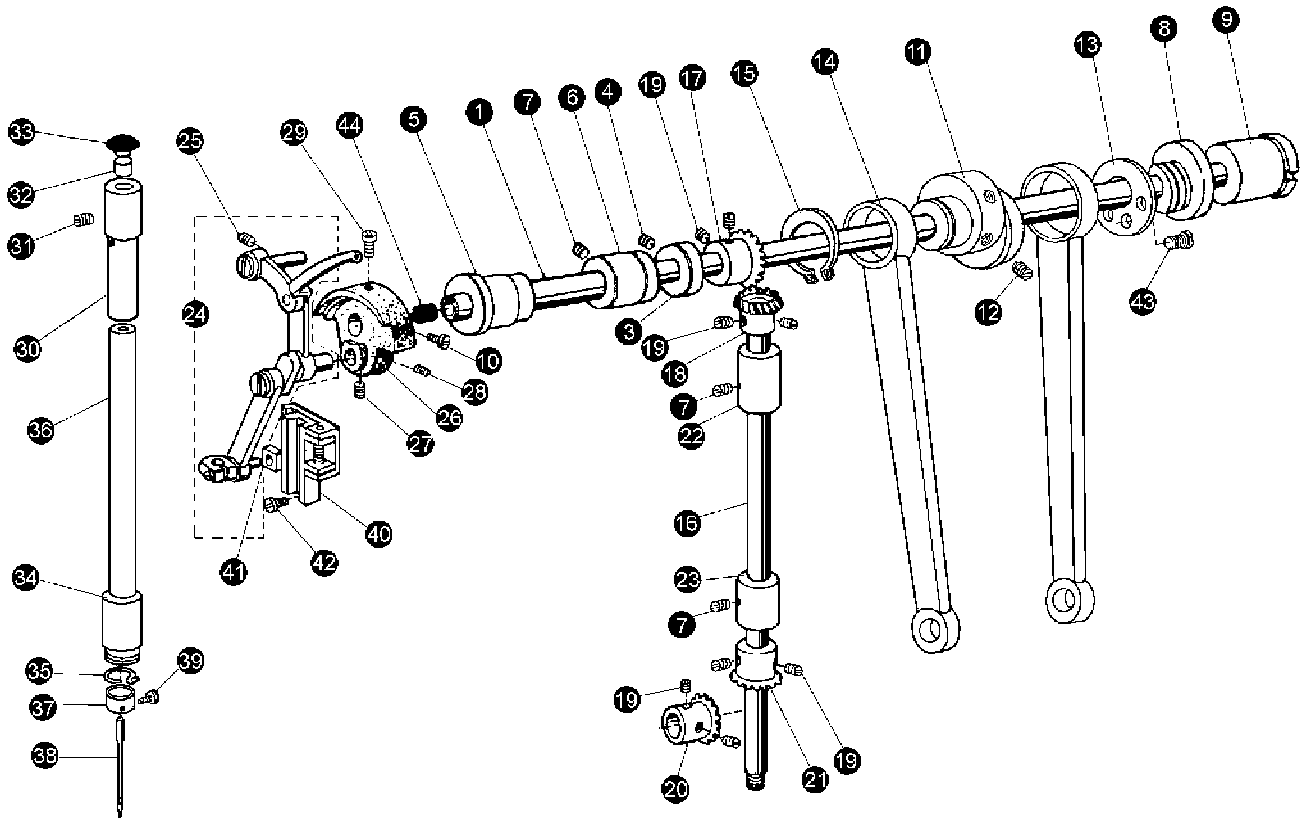

2. ARM SHAFT AND VERTICAL SHAFT AND THREAD TAKE – UP MECHANISM

No.	Ref. No.	Description	Qt.		
			M	H	B
1	153310001	Arm shaft	1	1	1
2	22T3 – 001A2	Rubber plug	1	1	1
3	22T3 – 002B1	Collar for arm shaft	1	1	1
4	22T2 – 005B2	Screw	2	2	2
5	22T3 – 003	Arm shaft bushing (left)	1	1	1
6	22T3 – 004	Arm shaft bushing (middle)	1	1	1
7	22T2 – 002	Screw	3	3	3
8	108300005	Arm shaft bushing(right)	1	1	1
9	124T3 – 003C2	Oil seal	1	1	1
10	22T2 – 006	Screw	1	1	1
11	36T3 – 003	Eccentric wheel	1		
	114T3 – 001	Eccentric wheel		1	1
12	22T1 – 013	Eccentric wheel screw	2	2	2
13	36T3 – 004	Spacer	1	1	1
14	22T3 – 009D1c	Crank rod for lifting rock shaft	1	1	1
15	36T3 – 004	Spacer	1	1	1
16	22T3 – 010E1	Vertical shaft	1	1	1
17	Z0A140379	Bevel gear for arm shaft	1	1	1
18	Z0A140380	Bevel gear for vertical shaft (upper)	8	8	8
19	22T2 – 005B3	Set screw	1	1	1
20	Z0A140383	Bevel gear for hook shaft	1	1	1
21	Z0A140382	Bevel gear for vertical shaft (lower)	1	1	1
22	22T3 – 011	Vertical shaft bushing(upper)	1	1	1
23	22T3 – 012	Vertical shaft bushing(lower)	1	1	
	78T3 – 002	Vertical shaft bushing(lower)			1
24	22T2 – 001A	Needle bar link asm	1		
	48T2 – 001A	Needle bar link asm		1	
	78T2 – 001A	Needle bar link asm			1
25	22T2 – 002	Screw	1	1	1
26	22T2 – 005B1	Needle bar crank	1		
	48T2 – 002B	Needle bar crank		1	1
27	22T2 – 005B2	Screw	1	1	1
28	22T2 – 006	Screw	1	1	1
29	22T2 – 007	Set screw	1	1	1
30	22T2 – 008	Needle bar bushing(upper)	1	1	1
31	22T2 – 009	Screw	1	1	1
32	22T2 – 010	Felt plug	1	1	1
33	22T2 – 011	Rubber plug	1	1	1
34	22T2 – 012C1	Needle bushing(lower)	1		
	124T2 – 006	Needle bushing(lower)		1	1
35	22T2 – 012C2	Thread guide	1	1	1
36	22T2 – 014	Needle bar	1		
	78T2 – 004	Needle bar		1	1
	153200001	Needle bar	1		
37	22T2 – 015	Thread guide for needle bar	1		
	48T2 – 004	Thread guide for needle bar		1	1
38	DB ×1 14#	Needle	1		
	DP ×5 18#	Needle		1	
	DP ×1 22#	Needle			1
	DP ×5 14#	Needle	1		
39	22T2 – 017	Screw	1	1	1
40	36T3 – 005E	Guide rail for slide block	1	1	1
41	22T2 – 020	Slide block	1	1	1
42	22T2 – 019	Set screw	2	2	2
43	100T6 – 012	Screw	3	3	3
44	124T3 – 001A2	Screw	1	1	1
45	22T3 – 008	Screw	1	1	1
46	124T3 – 001A5	Oil seal	1	1	1

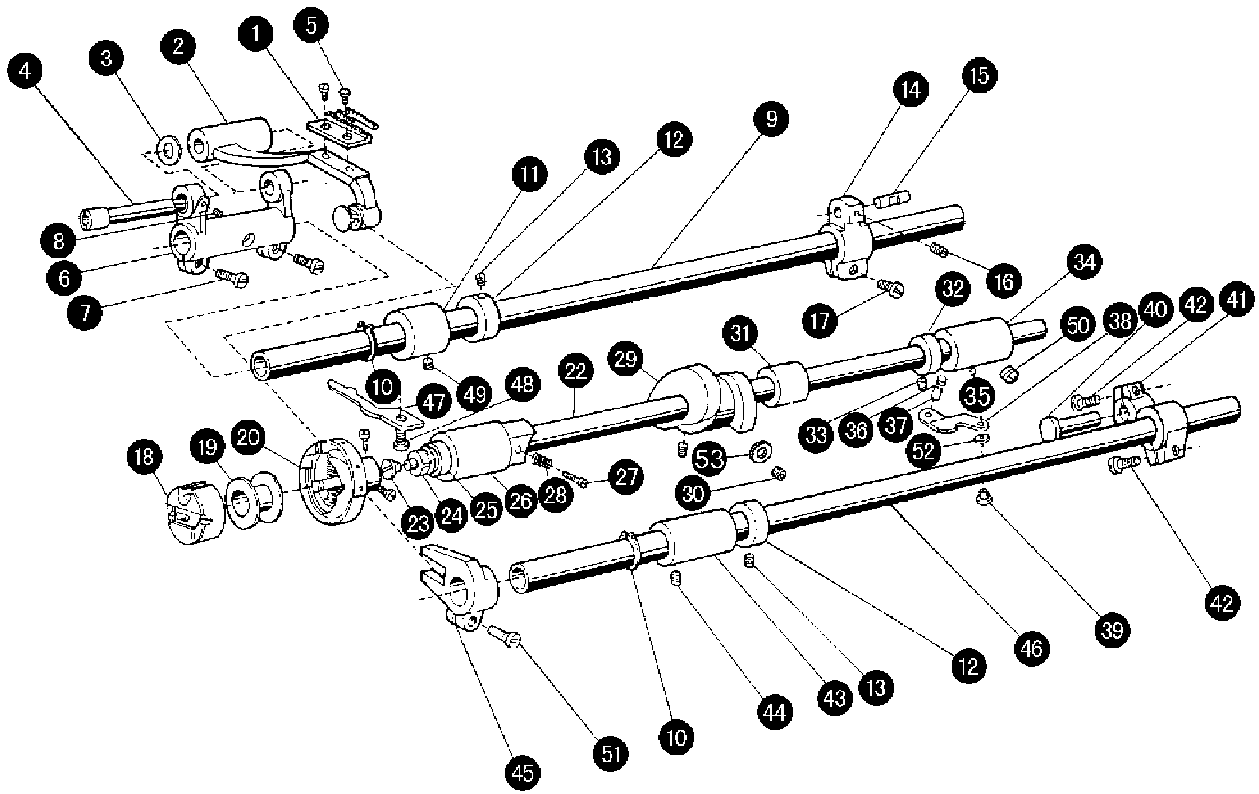

3. FEEDING AND FEED LIFTING AND ROTATING HOOK MECHANISM

No.	Ref. No.	Description	Qt.		
			M	H	B
1	22T6 -001A3	Feed dog	1	1	1
	22T6 -0012	Feed dog	1		
	153600001	Feed dog		1	1
2	36T4 -001A1a	Feed bar	1	1	1
3	22T6 -001A6	Washer	1	1	1
4	36T4 -001A2	Shaft for feed bar	1	1	1
5	22T6 -001A4	Screw	2	2	2
6	22T6 -001A1a	Feed rock shaft crank	1	1	1
7	22T6 -001A1b	Screw	2	2	2
8	22T2 -019	Screw	1	1	1
9	124T6 -002	Feed rock shaft	1	1	1
10	GB894 -86 -15	C -type stop ring	2	2	2
11	22T6 -004	Bushing for feed rock shaft	1	1	1
12	22T6 -005B1	Collar for feed rock shaft	2	2	2
13	22T3 -002B2	Screw	4	4	4
14	36T4 -003	Feed rock shaft crank (right)	1		
	114T4 -001	Feed rock shaft crank (right)		1	1
15	36T4 -004H01	Pin	1	1	1
16	36T5 -008E5	Screw	1	1	1
17	22T6 -008D3	Screw	1	1	1
18	36T4 -005B	Bobbin case complete	1	1	
	78T4 -004F	Bobbin case complete			1
19	36T4 -006	Bobbin	1	1	
	78T4 -005	Bobbin			1
20	36T4 -007C	Rotating hook complete	1	1	
	78T4 -002	Rotating hook complete			1
22	36T4 -008D1	Hook shaft	1	1	
	120T4 -001	Hook shaft			1
23	22T4 -001A1a1	Filter screw	1	1	1
24	22T4 -001A1a2	Filter	1	1	1
25	36T4 -009G	Oil seal	1	1	1
26	36T4 -010	Hook shaft bushing(left)	1	1	1
27	22T4 -005	Oil adjusting screw	1	1	1
28	22T4 -006	Coil spring	1	1	1
29	36T4 -011E1	Thread cutting cam	1	1	1
30	36T4 -011E2	Screw	2	2	2
31	36T4 -012	Hook shaft bushing(middle)	1	1	1
32	22T4 -002B1	Collar for hook shaft	1	1	1
33	22T2 -009	Screw	2	2	2
34	36T4 -014F1	Hook shaft bushing(right)	1	1	1
35	22T4 -007C2	Oil pipe for hook shaft bushing	1	1	1
36	36T4 -015	Plunger	1	1	1
37	36T4 -016	Plunger spring	1	1	1
38	22T4 -010	Guide plate	1	1	
	78T4 -006	Guide plate			1
39	22T5 -001A4	Screw	1	1	1
40	22T6 -008D2	Hinge pin	1	1	1
41	36T4 -017	Feed lifting rock shaft crank(right)	1	1	1
42	22T6 -016	Screw	2	2	2
43	22T6 -012	Bushing for feed lifting shaft(left)	1	1	1
44	22T2 -002	Screw	1	1	1
45	36T4 -018H1D1	Feed lifting fork	1	1	1
46	124T6 -003	Feed lifting rock shaft	1	1	1
47	22T4 -013	Hook positioner	1		
	48T4 -002	Hook positioner		1	
	78T4 -003	Hook positioner			1
48	22T4 -015	Screw	1	1	1
49	22T2 -009	Screw	1	1	1
50	22T1 -002	Screw	1	1	1
51	22T6 -008D3	Screw	1	1	1
52	GB93 -87 -6	Washer	1	1	1

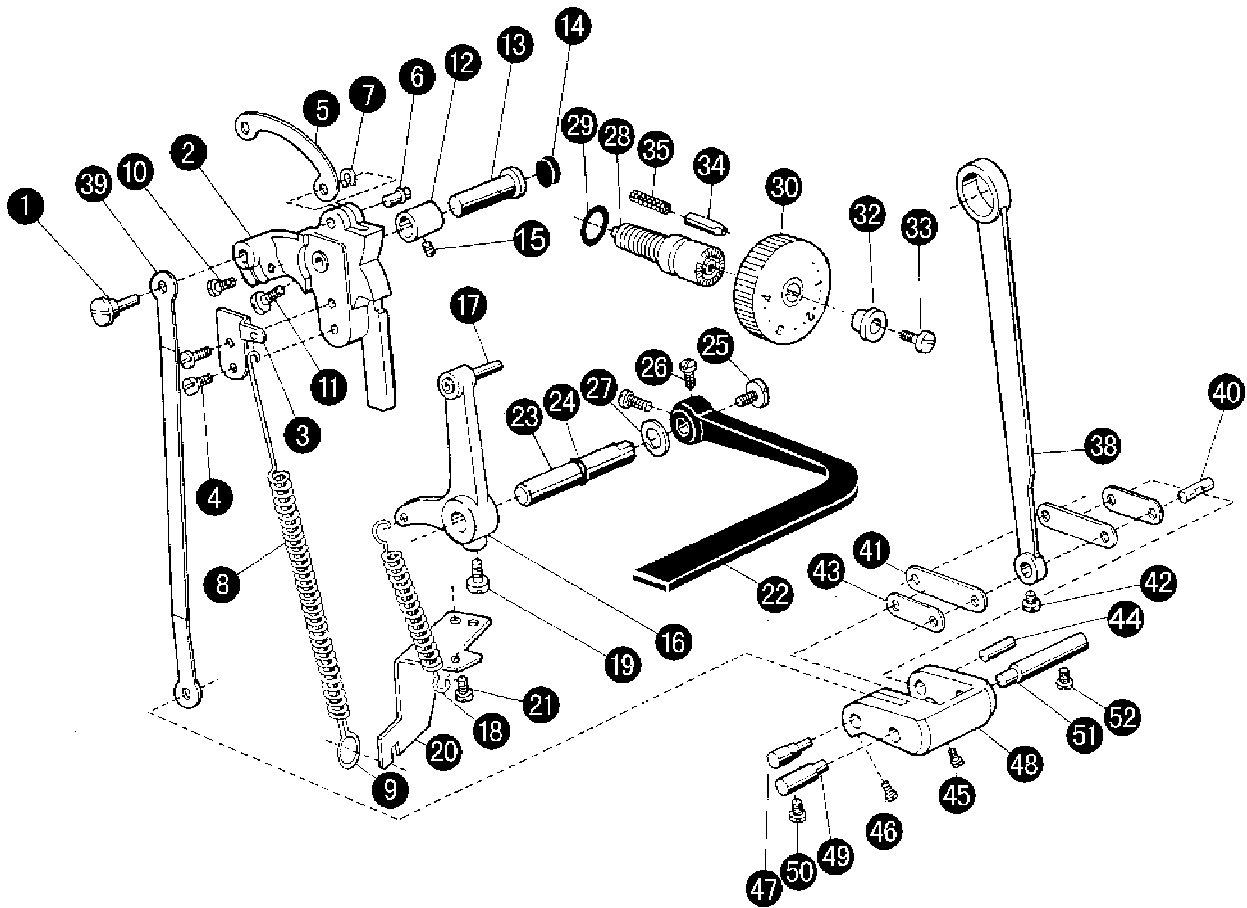

4. STITCH LENGTH REGULATING MECHANISM

No.	Ref. No.	Description	Qt.		
			M	H	B
1	36T5 - 001	Set pin	1	1	1
2	36T5 - 002A1	Feed regulator	1		
	114T5 - 001	Feed regulator		1	1
3	36T5 - 002A2	Spring retainer	1	1	1
4	22T2 - 019	Screw	2	2	2
5	36T5 - 002A3	Link	1	1	1
6	36T5 - 002A4	Pin	1	1	1
7	GB896 - 85 - 4	Split retaining ring	1	1	1
8	36T5 - 002A5	Coil spring	1	1	1
9	36T5 - 002A6	Spring holder	1	1	1
10	22T6 - 008D3	Screw	1	1	1
11	22T5 - 010D4	Screw	1	1	1
12	22T5 - 003	Bushing for feed regulator	1	1	1
13	22T5 - 004	Pin shaft	1	1	1
14	36T5 - 003	Rubber plug	1	1	1
15	22T2 - 002	Set screw	1	1	1
16	36T5 - 004B1	Reverse sewing crank	1	1	1
17	36T5 - 004B2	Reverse sewing crank shaft	1	1	1
18	36T5 - 004B3	Coil spring	1	1	1
19	22T5 - 013	Screw	1	1	1
20	36T5 - 005	Spring holder	1	1	1
21	22T5 - 001A4	Screw	1	1	1
22	22T5 - 010D1	Reverse sewing lever	1	1	1
23	36T5 - 006C1a1	Shaft for reverse sewing lever	1	1	1
24	GB3452. 1 - 92	O - type ring 6. 3 × 1. 8d	1	1	1
25	22T5 - 010D3	Screw	1	1	1
26	22T5 - 010D4	Screw	2	2	2
27	22T5 - 011	Washer	1	1	1
28	124T5 - 001A2	Screw bar	1	1	1
29	124T5 - 001A3	O - type rubber ring	1	1	1
30	27500001	Dial	1		
	124T5 - 001A5	Dial		1	1
32	36T5 - 007D4	Bushing	1	1	1
33	36T5 - 007D5	Screw	1	1	1
34	36T5 - 012	Thrust pin	1	1	1
35	22T5 - 009	Coil spring	1	1	1
38	36T5 - 008E2	Feed link	1	1	1
39	36T5 - 008E3	Stitch length regulating link	1	1	1
40	36T4 - 004H02	Pin (Long)	1	1	1
41	36T5 - 008E4H02	Link (Long)	2		
	114T5 - 003	Link (Long)		2	2
42	36T5 - 008E5	Screw	1	1	1
43	36T5 - 008E4H01	Link (short)	2	2	2
44	36T5 - 008E6	pin (short)	1	1	1
45	36T5 - 008E7	Screw	1	1	1
46	36T5 - 008E8	Screw	1	1	1
47	36T5 - 008E9	Eccentric shaft	1	1	1
48	36T5 - 008E10	Stitch length adjusting crank	1	1	1
49	36T5 - 009H02	Set pin (left)	1	1	1
50	22T6 - 008D3	Screw	1	1	1
51	36T5 - 009H01	Set pin (right)	1	1	1
52	22T6 - 008D3	Screw	1	1	1

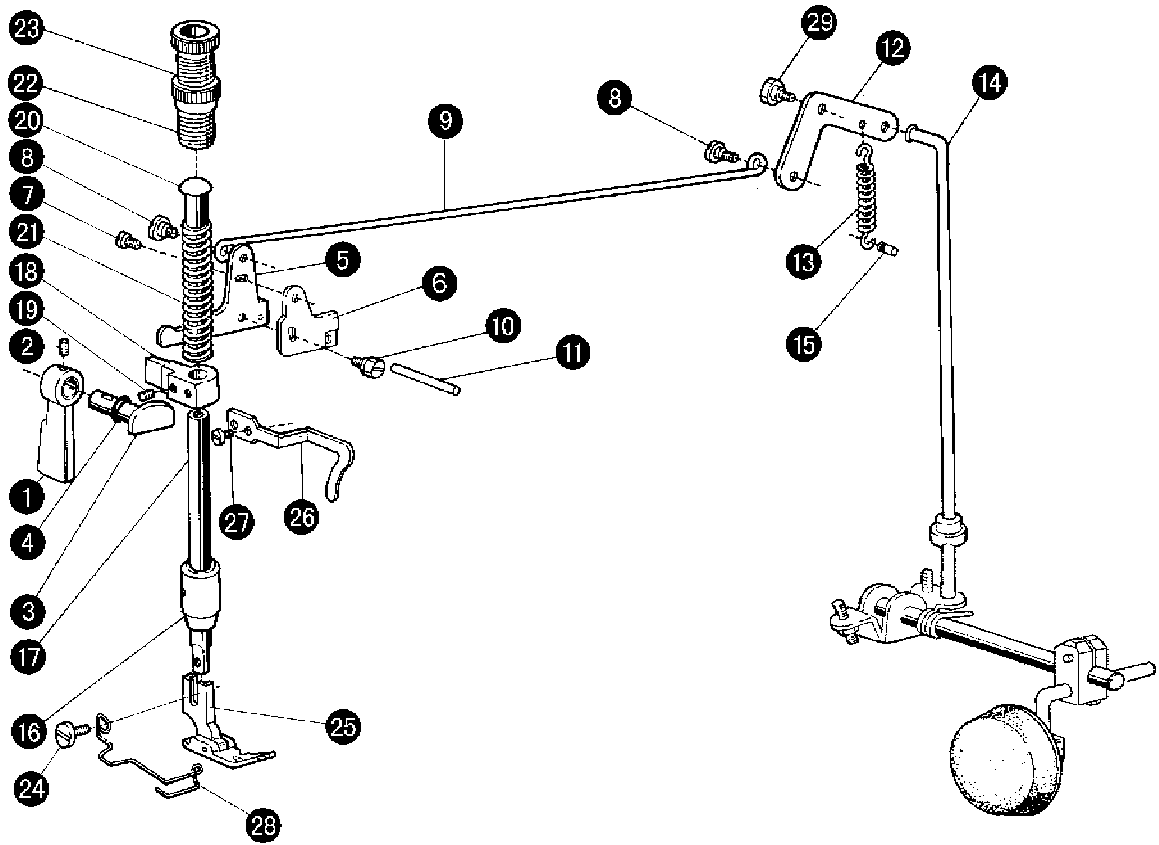

5. PRESSER FOOT MECHANISM

No.	Ref. No.	Description	Qt.		
			M	H	B
1	36T6 - 001A1	Presser bar lifter	1	1	1
2	J0. 0. 35	Screw	1	1	1
3	36T6 - 002B1	Presser bar lifting cam	1	1	1
4	GB3452. 1 - 92	Oil seal(4. 5 × 1. 8G)	1	1	1
5	36T6 - 003C1a1	Knee lifter lever (left)	1	1	1
6	22T7 - 004B1b	Tension releasing cam	1	1	1
7	22T7 - 004B1c	Screw	1	1	1
8	22T7 - 004B2	Screw	2	2	2
9	22T7 - 004B3	Knee lifter rod	1	1	1
10	22T7 - 005	Screw	1	1	1
11	36T6 - 004	Thread releasing pin	1	1	1
12	22T7 - 007C1	Knee lifter lever (right)	1	1	1
13	22T7 - 007C2	Coil spring	1	1	1
14	22T7 - 007C3	Knee lifter connecting rod	1	1	1
15	22T7 - 008	Pin for spring	1	1	1
16	22T7 - 009	Bushing for presser bar	1	1	1
17	22T7 - 010	Presser bar	1	1	1
18	22T7 - 011D1	Presser bar guide bracket	1	1	1
19	22T1 - 013	Screw	1	1	1
20	22T7 - 012	Presser bar spring guide	1	1	1
21	48T7 - 002	Presser bar spring	1	1	1
22	22T7 - 014E1	Thumb screw	1	1	1
23	22T7 - 014E2	Lock nut	1	1	1
24	22T7 - 015	Screw	1	1	1
25	22T7 - 017F	Presser foot asm	1		
	48T7 - 003A	Presser foot asm		1	1
	027701100	Presser foot asm		1	1
26	22T7 - 16	Thread guide	1	1	1
27	22T2 - 004	Screw	1	1	1
28	57T7 - 002	Presser foot spring	1	1	1
29	22T7 - 007C4	Screw	1	1	1

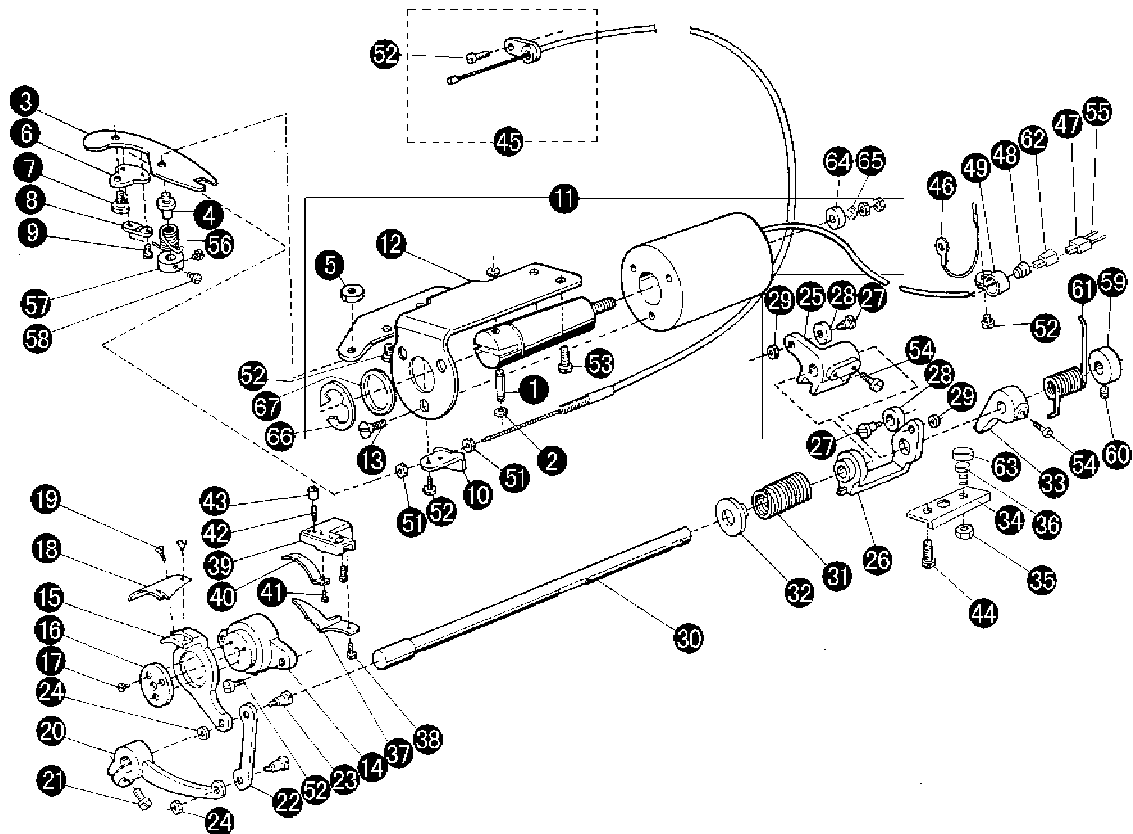

6. KNIFE ACTUATING MECHANISM

No.	Ref. No.	Description	Qt.		
			M	H	B
1	36T8 - 009	Pin	1	1	1
2	GB896 - 85 - 4	Split retaining ring	2	2	2
3	36T7 - 001A1	Flexible driving lever	1	1	1
4	36T7 - 001A2	Screw	1	1	1
5	JO. O. 16	Nut	1	1	1
6	36T7 - 001A3	Bracket for flexible bracket	1	1	1
7	36T7 - 001A4	Screw	1	1	1
8	36T7 - 001A5	Flexible wire connecting bracket	1	1	1
9	36T7 - 001A6	Screw	2	2	2
10	36T7 - 001A7	Holder for flexible wire	1	1	1
11	165710000	Solenoid assy for thread trimmer	1	1	1
12	36T7 - 001A8b	Solenoid mounting bracket	1	1	1
13	GB68 - 85 - M4 x 6	Screw	3	3	3
14	36T7 - 002B1a1	Knife holding saddle	1	1	1
15	36T7 - 002B1a2	knife base (left)	1	1	
	120T7 - 001A1	knife base (left)			1
16	36T7 - 002B1a3	Washer	1	1	1
17	36T7 - 002B1a4	Screw	3	3	3
18	36T7 - 002B2	Blade (left)	1	1	
	120T7 - 001A2	Blade (left)			1
19	36T7 - 002B3	Set screw	2	2	2

6. KNIFE ACTUATING MECHANISM

No.	Ref. No.	Description	Qt.		
			M	H	B
20	36T7 - 002B4	Knife driving crank	1	1	1
21	61 - 04 - 01 / B6	Screw	1	1	1
22	36T7 - 002B5	Link	1	1	1
23	36T7 - 002B6	Screw	2	2	2
24	36T7 - 002B7	Nut	2	2	2
25	36T7 - 003C1	Cam follower crank(1)	1	1	1
26	36T7 - 003C2	Cam follower crank(2)	1	1	1
27	36T7 - 003C3	Roller stud	2	2	2
28	36T7 - 003C4	Roller stud	2	2	2
29	36T7 - 003C5	Nut stud	2	2	2
30	36T7 - 004	Knife driving shaft	1	1	
	120T7 - 002	Knife driving shaft			1
31	36T7 - 005	Coil spring	1	1	1
32	36T7 - 006	Bushing	1	1	1
33	165720004	Stopper	1	1	1
34	165720001	Stopper plate	1	1	1
35	GB6172 - 86 - 6	Nut	1	1	1
36	165720002	Screw	1	1	1
37	36T7 - 009E1	Thread guide	1	1	
	120T7 - 003B1	Thread guide			1
38	JO. 0. 72	Screw	1	1	1
39	36T7 - 009E2	Bracket for fixed blade	1	1	1
40	36T7 - 009E3	Fixed knife	1	1	
	120T7 - 003B2	Fixed knife			1
41	36T7 - 009E4	Set screw	1	1	1
42	36T7 - 009E5	Adjusting screw	1	1	1
43	36T7 - 009E6	Adjusting nut	1	1	1
44	36T8 - 002	Set Screw	2	2	2
45	36T7 - 010F	Flexible wire asm	1	1	1
46	36T7 - 011G	Earth wire asm	1	1	1
47	36T7 - 012	Plug	1	1	1
48	36T7 - 013	Rubber sleeve	1	1	1
49	36T7 - 014	Wire clamp	1	1	1
50	GB848 - 86	Washer 4	1	1	1
51	GB54 - 86 - M5	Nut	2	2	2
52	22T2 - 019	Screw 4. 37 x40/8	8	8	8
53	36T8 - 002	Screw	2	2	2
54	22T5 - 010D4	Screw	3	3	3
55	36T9 - 001A2a2	Pin	2	2	2
56	36T7 - 001A9	Coil spring	1	1	1
57	36T7 - 001A10	Collar for driving lever	1	1	1
58	36T5 - 008E8	Screw	2	2	2
59	36T7 - 015H1	Collar for knife driving shaft	1	1	1
60	22T3 - 002B1	Screw	1	1	1
61	36T7 - 016	Coil spring	1	1	1
62	36T7 - 017	Guard for plug	1	1	1
63	165720003	Rubber washer	1	1	1
64	1657100001	Rubber washer	1	1	1
65	GB96 - 85 - 5	Washer	1	1	1
66	GB96 - 86 - 12	Split retaining ring	1	1	1
67	36T7 - 001A8a1	Washer	1	1	1

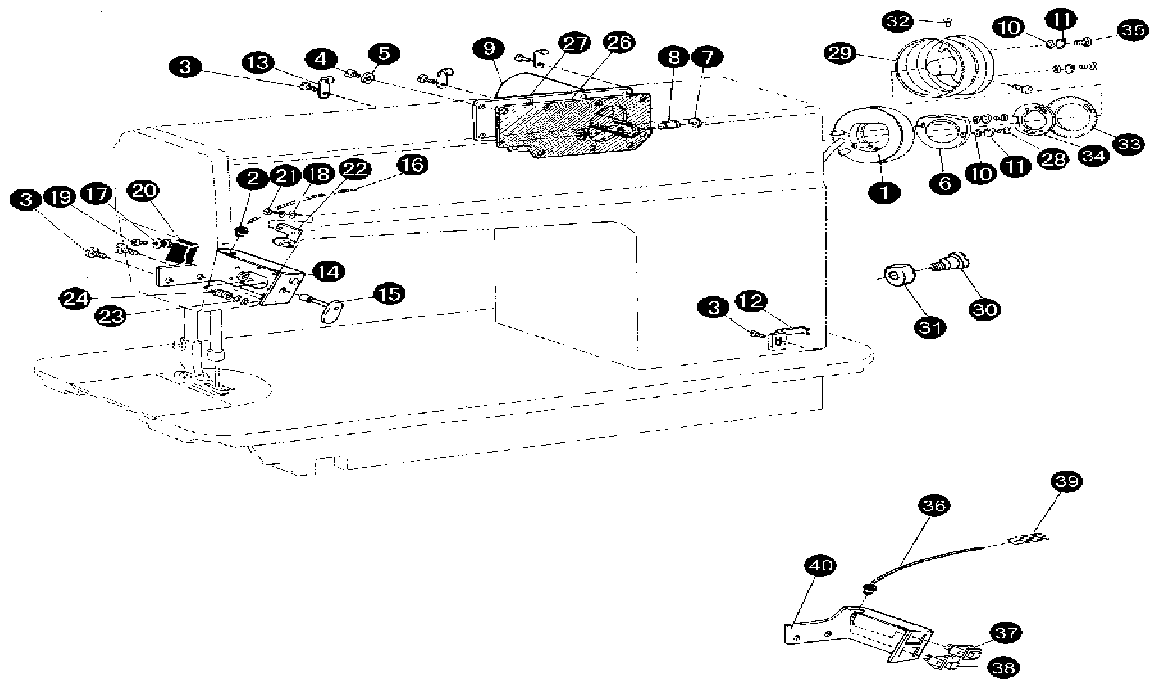

7. REVERSE SEWING AND DETECTOR MECHANISM

No.	Ref. No.	Description	Qt.		
			M	H	B
1	108910000	Detector componts	1	1	1
1	108930000	Detector componts	1	1	1
2	36T7 -013	Rubber plug	1	1	1
3	22T2 -019	Screw	2	2	2
4	22T1 -006	Screw	6	6	6
5	22T1 -007	Washer	8	8	8
6	185A20001	Detector presser plate	1	1	1
7	GB896 -86	Split washer 4	2	2	2
8	36T8 -009	Pin	1	1	1
9	36T8 -008E4b	Electric - magnet for reverse sewing	1	1	1
10	GB848 -85 - 4	Washer	2	2	2
11	GB893 -87	Spring washer 3	2	2	2
12	36T8 -005	Cord holder	1	1	1
13	108800101	Wire clamp	1	1	1
	108800201	Wire clamp	1	1	1
	108800301	Wire clamp	1	1	1
14	36T8 -007C1	Switch bracket	1	1	1
15	36T8 -007C2a	Button asm	1	1	1
16	36T8 -007C3b	Cable for switch at reverse sewing	1	1	1
17	GB859 -86 - 2	Spring washer 2	2	2	2
18	GB848 -86 - 2	Washer 2	2	2	2
19	GB818 -85 - M2x8	Screw	2	2	2
20	36T8 -007C4	Micro switch	1	1	1
21	GB66 -76	Screw	2	2	2
22	36T8 -007C5	Leaf spring	1	1	1
23	GB896 -86 - 3	Split retaining ring	2	2	2
24	36T8 -007C6	Coil spring	1	1	1
26	36T8 -008E1	Gasket	1	1	1
27	165820001	Side cover	1	1	1
28	22T6 -008D3	Screw	2	2	2
29	165320001	Balance wheel asm	1	1	1
30	36T8 -004B1	Screw	1	1	1
31	36T8 -004B2	Washer	1	1	1

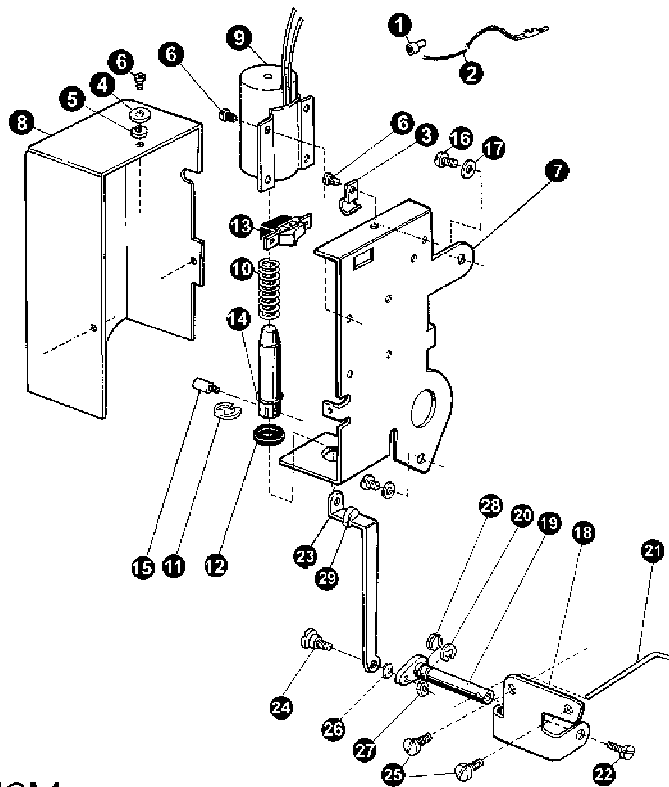

8. WIPER MECHANISM

No.	Ref. No.	Description	Qt.		
			M	H	B
1	36T9 - 001A1	Wire connector	1	1	1
2	36T9 - 001A2a	Wire	1	1	1
3	36T9 - 001A3	Cord clamp	1	1	1
4	GB848 - 86 - 3	Washer	8	8	8
5	GB859 - 86 - 3	Washer	8	8	8
6	GB818 - 86	Screw M3 x6	8	8	8
7	36T9 - 001A4	Solenoid bracket	1	1	1
8	36T9 - 001A5	Cover for wiper mech	1	1	1
9	36T9 - 001A6	Solenoid for wiper	1	1	1
10	36T9 - 001A7	Coil spring	1	1	1
11	GB896 - 86 - 9	Retaining ring	1	1	1
12	36T9 - 001A8	Rubber ring	1	1	1
13	36T9 - 001A9	Switch for wiper	1	1	1
14	36T9 - 001A10	Washer	1	1	1
15	36T9 - 002	Screw	1	1	1
16	22T5 - 001A4	Screw	2	2	2
17	36T9 - 003	Washer	2	2	2
18	36T9 - 004B1	Wiper bracket	1	1	1
19	036921008	Wiper shaft asm	1	1	1
20	G896 - 86 - 4	Retaining ring	2	2	2
21	36T9 - 004B3	Wiper	1	1	1
22	22T6 - 001A4	Screw	1	1	1
23	36T9 - 004B4	Link	1	1	1
26	036921006	Washer	1	1	1
25	36T9 - 005	Screw	2	2	2
24	036921007	Shaft	1	1	1
28	036921005	Washer	1	1	1
27	GB6170 - 86	Nut M3	1	1	1
29	165900001	Rubber washer	1	1	1

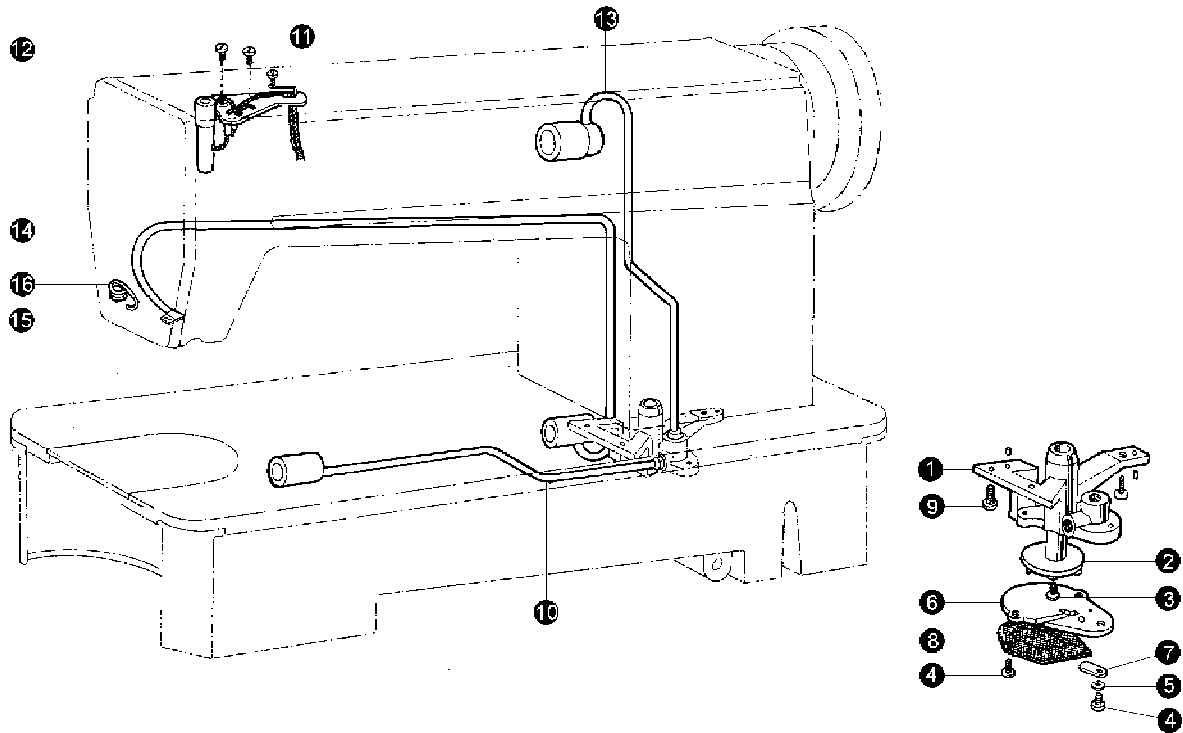

9. OIL PUMP MECHANISM

No.	Ref. No.	Description	Qt.		
			M	H	B
1	22T8 - 001	Oil pump	1	1	1
2	22T8 - 002	Oil pump impeller	1	1	1
3	22T8 - 003	Screw	1	1	1
4	22T8 - 004	Screw	3	3	3
5	GB93 - 87 - 3	Springee washer	1	1	
6	22T8 - 006	Oil pump fitting plate	1	1	
7	22T8 - 007	Oil adjusting plate	1	1	
8	22T8 - 008A	Oil pump screen asm	1	1	1
9	22T8 - 009	Screw	3	3	3
10	36T10 - 001A	Oil pump for hook shaft	1	1	1
11	22T8 - 011C	Oil braid fitting plate	1	1	1
12	22T8 - 015	Screw	2	2	2
13	22T8 - 013D	Oil pump for arm shaft	1	1	1
14	22T8 - 014	Oil return pipe	1	1	1
15	22T8 - 015	Felt pouch for return oil filter	1	1	1
16	36T10 - 002	Oil filter holder	1	1	1

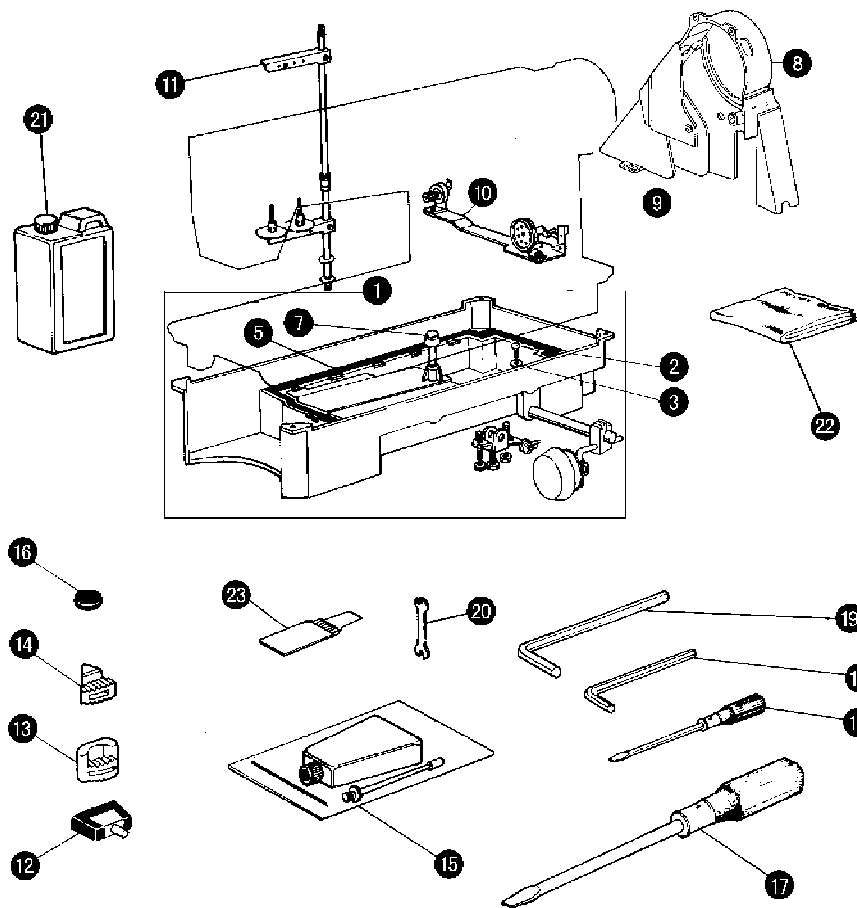

10. OIL RESERVOIR AND ACCESSORIES

No.	Ref. No.	Description	Qt.		
			M	H	B
1	36T11 - 001A	Oil reservoir asm	1	1	1
2	22T9 - 001A2	Screw	1	1	1
3	22T9 - 001A3	Washer	1	1	1
5	22T9 - 001A5	Oil gasket	1	1	1
7	22T9 - 003B1	knee lifter lifting pin	1	1	1
8	124T9 - 003B	Belt cover	1	1	1
9	124T9 - 004C	Belt cover (S)	1	1	1
10	6F0	Thread winder asm (large hook)	1	1	1
11	GXJ - 2	Thread spool asm	1	1	1
12	22T9 - 007F	Hinge with rubber cushion	2	2	2
13	22T9 - 009	Cushion (B)	2	2	2
14	22T9 - 010	Cushion (S)	2	2	2
15	22T9 - 011	Oil pot	1	1	1
16	22T9 - 012	Magnet block	1	1	1
17	22T9 - 013	Screw drive (long)	1	1	1
18	22T9 - 015	Screw drive (short)	1	1	1
19	36T11 - 006	Allen wrench M4	1	1	1
	36T11 - 006	Allen wrench M6	1	1	1
20	22T9 - 016	Double open -end wrench	1	1	1
21	22T9 - 017	Oil tank	1	1	1
22	22T9 - 018	Machine head cover	1	1	1
23	22T9 - 024	Needle bag	1	1	1

GC6180 series machine's main technical data

Model		M	H	B
Item				
Application		Common materials	Thick materials	Thick materials
Sewing speed		5000 S. P. M.	3500 S. P. M	3000 S. P. M
Max. stitch length		4mm	7 mm	
Presser foot lift	By hand	6 mm		
	By knee	13 mm		
Needle		DB x1 -2 9#-16#	DP x5 18#-22#	
Rotating shuttle		Standard automatic oiling	Thick materials automatic oiling	Twice automatic oiling
Detector		Inside		
Operation panel		Outside		
Motor		400W motor with eddy current speed adjusting section		
Other		Can select automatic foot lifter system		

When sewing at speeds of 3000 rpm or higher, set the stitch length to 5 mm or less.

- Besides adjusting stitch, please laypeople don't debug or maintain machine.
- Parts are subject to changes in design without prior notice.

XI'AN TYPICAL INDUSTRIES CO., LTD.

Add: No. 1 Taibai South Road,
 Xi'an, P. R. China - 710068
 Tel : +86 -29 -88279091 88279150
 Fax : +86 -29 -88249715 88245215
 E-mail: typical@chinatypical.com
 Http: www.chinatypical.com
 Http: www.globalsources.com

2004. 12. 26 ②